

SERIES 35-71



120 VAC Microprocessor Based Direct Spark Ignition Control with Combustion Blower Relay

35.71.02

FEATURES

- 3 Enclosure Configurations
 - Case and Cover - dust and foreign object protection
 - Open Board with Stand-offs - saves space and cost
 - Potted - protection for washdown and extreme vibration
- Full-time power option
- Integral Blower Relay
- 2 Wiring Options – 1/4" quick connects and multi-pin connector
- 2 Trial For Ignition Options - 1 and 3 trial
- 4 Trial For Ignition Times - 4, 7, 10 and 15 seconds (customized timings available)
- 2 Flame Sense Options – single spark and sense and remote sense
- Diagnostic LED - 3 error codes for accurate troubleshooting
- Flame Current Test Pins - instant access to circuit for troubleshooting
- Polarity Insensitive – reduces chance of miswiring

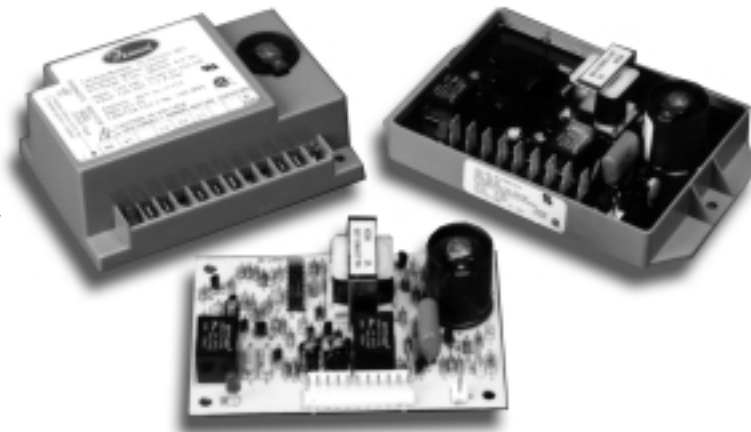

APPLICATIONS

- Construction and Agriculture Heaters
- Crop Dryers
- Ceramic and Black Body Infrared Heaters
- Commercial Cooking Equipment
- Any 120 VAC Gas Burner Application under 400K BTU

DESCRIPTION

The 35-71 is a 120 VAC direct spark ignition control with blower relay for controlling a gas valve, controlling and monitoring combustion air-flow and igniting LP or natural gas for construction heaters, infrared heaters, crop dryers, commercial cooking equipment and gas burner applications that provide a 120 VAC operating signal.

The microprocessor circuit design provides precise, repeatable timing sequences for ignition times and purge times (pre-, inter- and post-) as well as multiple tries for ignition, 1 hour automatic reset and flame sensing during pre-, inter- and post-purge. The control continually monitors the pressure switch, thermostat and main burner flame to ensure safe system operation. The on-board diagnostics with LED output provide assistance with troubleshooting to ensure safe and efficient burner operation.

Agency Certifications



Recognized under the Component Program of Underwriters Laboratories Inc., UL 372, UL 1998 Software



Design certified by CSA International, CAN C22.2 #199-M89 and ANSI Z21.20 Automatic Ignition Systems

THE TOTAL SOLUTION FOR GAS IGNITION CONTROL

Fenwal offers a complete range of ignition control products including:

- Ignition Controls
- Spark and Flame Sense Electrodes
- Spark and Flame Sense Cables
- Wiring harnesses

Designed, developed and manufactured by Fenwal, these components integrate seamlessly providing maximum system performance.

Getting Started - Samples

To ensure proper system design and operation, Fenwal provides sample ignition controls, high-voltage wires and electrodes for trial and evaluation at no charge. To get you started quickly, Fenwal has identified our most popular ignition controls, see Page 8. Whether it is an individual control, complete start-up kit or customized control, Fenwal is ready to provide your gas ignition solution.

Fenwal Ignition Development Center

Send your equipment to us and we'll design, install and qualify a control to meet your exact application requirements. Fully equipped and staffed with trained technicians, the Fenwal Ignition Development Center has proven extremely beneficial for many customers focused on product quality and reducing time-to-market for their appliances.

SEQUENCE OF OPERATION / FLAME RECOVERY/ SAFETY LOCKOUT

Start up - Heat Mode

120 VAC is supplied to the L1 terminal, either from a thermostat or other control device. When this occurs the control will power up and perform a self-check routine and if selected, begin a pre-purge. Following the pre-purge, the gas valve is energized and sparks commence until flame is detected or the Trial for Ignition (TFI) period expires.

When flame is detected, the spark is shut off and the gas valve and combustion blower remain energized. The thermostat, pressure switch and main burner flame are constantly monitored to ensure that the system is functioning properly. When the thermostat is satisfied and the demand for heat ends, the gas valve is de-energized immediately and a post-purge is initiated (optional) and the flame is extinguished. When the post purge is complete, the combustion blower is de-energized.

System Response to Flame Failures

Fenwal controls are configured with several options for managing loss of flame.

Failure during TFI Period

SINGLE TRIAL MODEL

Should the burner fail to light or flame is not detected during the TFI period, the gas valve is de-energized and the control will go into lockout mode.

MULTI TRIAL MODEL

Should the burner fail to light or flame is not detected during the first TFI period, the gas valve is de-energized and the control will attempt two additional ignition trials with inter-purge. If these attempts are unsuccessful, the control will go into lockout mode.

Failure of Established Flame - Two Options

There are two methods for re-starting the burner after loss of established flame. The Re-ignition option is the default configuration for re-establishing flame and does not need to be specified when ordering. If the Recycle option is desired, please specify this when ordering so that a special part number is assigned to the control by Fenwal.

RE-IGNITION

If the established flame signal is lost, the control responds and begins sparking within 0.8 seconds of loss of flame. This is considered the first re-ignition attempt. The spark will be energized for the duration of the TFI period in an attempt to re-light the burner. If flame is re-established, normal operation resumes.

SINGLE TRIAL MODEL

If the burner does not light after the first re-ignition attempt, the control will de-energize the gas valve and go into lockout mode.

MULTI TRIAL MODEL

If the burner does not light after the first re-ignition attempt, the inter-purge sequence is completed between the next two attempts to re-light the burner. If the burner fails to light after the third attempt, the control will de-energize the gas valve and go into lockout mode.

RECYCLE

If the established flame signal is lost, the control responds by shutting off the gas valve within 0.8 seconds.

SINGLE TRIAL MODEL

The control will begin the ignition cycle with the pre-purge cycle, if a pre-purge cycle is programmed into the control. Controls without pre-purge immediately commence sparking for one TFI period. If flame is re-established, normal operation resumes. If the burner fails to light after the first try, the control will de-energize the gas valve and go into lockout mode.

MULTI TRIAL MODEL

The control will begin the ignition cycle with the inter-purge sequence and attempt three tries for ignition including inter-purges. If flame is re-established, normal operation resumes. If the burner fails to light after the third try, the control will de-energize the gas valve and go into lockout mode.

NOTE: The Recycle feature option requires a special part number that is determined by contacting Fenwal.

Combustion Air Flow Monitoring

In normal operation, the control monitors the combustion air flow by reading the pressure switch (PSW) input to confirm that the blower is operating in the proper sequence. Initially, the control checks the PSW input to be sure that it is open. Once the blower is energized and the PSW closes the control proceeds to trial for ignition.

If during a call for heat 120 VAC power is present at the PSW input prior to the blower being energized, the control will wait 30 seconds, for the condition to change. Possible reasons for this condition includes a stuck or mis-wired pressure switch, or the blower is spinning down and keeping the switch closed. If the condition does not change, an airflow fault will be declared and the LED will flash the one flash pattern.

If the combustion blower is energized and the PSW does not close within 30 seconds, an airflow fault will be declared and the LED will flash the one-flash pattern. The blower will remain energized until the condition changes.

If the PSW signal is lost while the burner is firing, the control will immediately de-energize the gas valve and the combustion blower will remain on. If the call for heat remains and the PSW signal returns within 30 seconds, the control will restart with the pre-purge period. If the PSW input does not return within 30 seconds, the blower remains on and LED will flash the one-flash code indefinitely. If the PSW closes, the LED stops flashing and the control resumes operation with the pre-purge function.

Lockout Mode (On-Board Safety System)

After single or multiple attempts to light the burner have failed or flame is not established, the control automatically enters lockout mode. The control will not open the gas valve unless there is intervention by the user or one hour has passed depending on the model chosen. See Lockout Recovery.

Lockout Recovery - Two Options

There are two options for recovering from lockout mode. When selecting the control, please specify one of the following methods for lockout recovery.

1. Thermostat/ Power Off Reset- requires the user to reset the thermostat below ambient temperature or remove the 120 VAC power supply for 5 seconds. The control will start the ignition sequence and attempt to light the burner again.
2. Automatic Reset - After one hour, if the thermostat is still calling for heat, the control will automatically start the ignition sequence and attempt to light the burner again.

Benefits of Full Time Power

1. Separate 120 VAC input for ignition control operation and combustion blower operation. Allows high current to feed the blower directly rather than have it pass through the thermostat.
2. Sense flame even with zero second pre-purge to provide safe operation. Control will monitor flame presence immediately upon a call for ignition.
3. Post purge blower operation to clear the combustion chamber and remove remaining heat when the call for heat has ended.
4. If a flame is detected during pre-, inter- or post-purge, the combustion blower will be energized. Should the main valve later close and the flame signal disappear, the combustion blower will be de-energized.

MOUNTING AND WIRING

The 35-71 is not position sensitive and can be mounted vertically or horizontally. The control may be mounted on any surface and fastened with #6 sheet metal screws. Secure the control in an area that will experience a minimum of vibration and remain below the maximum ambient temperature of 80°C (175°F).

All connections should be made with UL approved, 105°C rated, 18 gauge, stranded, .054" thick insulated wire. Refer to the appropriate wiring diagram when connecting the 35-71 to other components in the system. High voltage spark cables and control wiring harnesses are detailed on Pages 5 and 6.

FULL TIME POWER

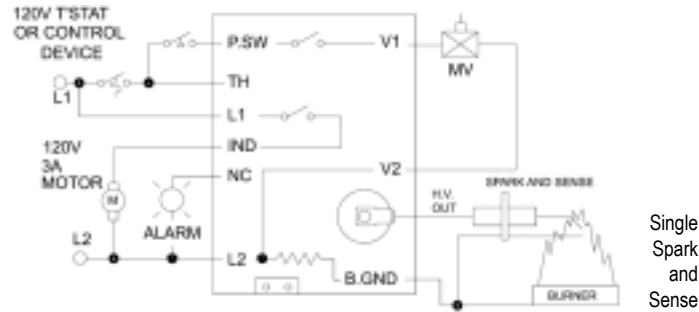

Single Spark and Sense

NO FULL TIME POWER

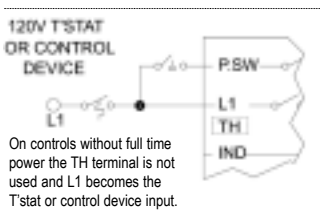

PIN LAYOUT

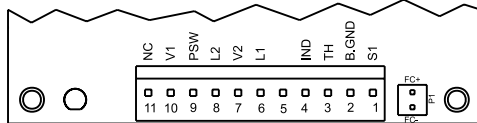

Terminal Designations

TERMINAL	DESCRIPTION	MULTI-PIN CONNECTOR P/N: AMP 1-644615-1		QUICK CONNECT TERMINAL SIZE
		PIN LOCATION	WIRE COLOR	
NC	Alarm	11	Blue	1/4"
V1	Valve Power	10	Brown	3/16"
PSW	Pressure Switch	9	Orange	1/4"
L2	120 VAC Neutral	8	White	3/16"
V2	Valve Neutral	7	Yellow	3/16"
L1	120 VAC Input (Hot)	6	Black	1/4"
IND	Inducer Output	4	White/Black	1/4"
TH	Thermostat Input	3	Red	1/4"
B.GND	Burner Ground	2	Purple	3/16"
S1*	Remote Flame Sensor	1	Gray	1/4"
FC+, FC-	Flame Sense Test Pins	2 Pin Header (AMP P/N: 640383-2, Molex P/N: 26-60-2020)		

* On controls configured for single spark and sense with quick connects, the S1 terminal is removed. On controls configured for single spark and sense with multi-pin connector, leave S1 wire, pin 1, color gray unconnected.



CAUTION: Label all wires prior to disconnection when servicing the control. Wiring errors can cause improper and dangerous operation. A functional checkout of a replacement is necessary to prevent property damage and/or personal injury or death.

WARNING: Operation outside specifications could result in failure of Fenwal product and other equipment with injury to people and damage to property and even death.

SPECIFICATIONS

Input Power	102 to 138 VAC, 50/60 Hz
Input Current Drain	350mA @ 120 VAC, 60 Hz
Gas Valve Rating	1.5A @ 120 VAC
Combustion Blower Rating	3.0 FLA @ 120 VAC
Operating Temperature	-40°F to +175°F, -40°C to +80°C
Flame Sense Voltage	120 VAC
Flame Sense Current	1.0 microamp minimum
Flame Failure Response Time	0.8 seconds maximum
Type of Gas	Natural, LP and manufactured
Spark Rate	Line frequency (50/60 Hz)
Moisture Resistance	Conformal coated to operate to 95% R.H.
Size (LxWxH)	See drawings on Page 8
Weight	Integral stand-offs: 7.1 oz Potted: 14.3 oz Case and Cover: 10.1oz

ON-BOARD DIAGNOSTICS

The LED will flash on for 0.2 seconds then off for 0.2 seconds to indicate an error condition. The pause time between error codes will be 2.5 to 3.0 seconds. During power-up, the LED will light for one second and then turn off to indicate normal operation.

LED Indication	Fault Mode
Steady on	Internal Control Failure
1 Flash	Airflow Fault
2 Flashes	Flame Fault**
3 Flashes	Ignition Lockout Fault

** May indicate either that a flame was detected during pre-, inter- or post-purge, or that there is a flame sensing error.

TROUBLESHOOTING GUIDE

SYMPTOM	RECOMMENDED ACTIONS
Control will not start up	A. Check for 120VAC at L1 and/ or TH B. Check fuse/ circuit breaker C. Check thermostat on and set above ambient D. Red LED steady on. Reset power. Replace control if LED remains on.
Gas Valve on and no spark during TFI	A. Shorted electrode - re-establish 1/8" gap B. Check that bracket is making a solid ground connection C. Check connection at each end of high voltage cable
Spark on and gas valve off	A. Check for 120VAC at V1 B. Check wiring to V1 and V2 C. Valve coil malfunction
Flame during TFI but no flame sense after TFI	A. Check that the spark electrode/ flame sensor are in the flame B. Poor ground at the burner C. Low flame current - check flame current using test pins on the control
Call for ignition, but combustion blower doesn't start up	A. Check for 120VAC at L1 and TH B. Check for 120VAC at IND, should be on if pressure switch is operating properly C. Check that the pressure switch has been wired properly D. Pressure switch failed off or on (1 LED Flash) E. Check blower fan assembly
Pressure switch operating properly, but no TFI after purge period	A. Flame was detected during purge period (2 LED Flashes) B. Check for 120VAC at L1 and TH C. Check for 120VAC at IND, should be on if pressure switch is operating properly

ACCESSORIES

Proper Electrode Location

Proper location of the electrode assembly is important for optimum system performance. It is recommended that the electrode assembly be mounted temporarily using clamps or other suitable means to check the system before permanently mounting the assembly. The electrode assembly should be located so that the tips are inside the flame envelope and about 1/2 inch (10 mm) above the base of the flame. See Figures 3a and 3b.

CAUTIONS:



1. Ceramic insulators should not be in or close to the flame.
2. Electrodes should have a gap spacing of 0.125 ± 0.031 inch (3.12 ± 0.81 mm). If this spacing is not correct, the assembly must be replaced or adjusted (see troubleshooting)
3. Exceeding the temperature limits can cause nuisance lockouts and premature electrode failure.
4. Electrodes must be placed where they are not exposed to the appliance user in normal operation.

Flame Sensing

Flame sensing is achieved using the principal of flame rectification. Flame rectification relies on the current passing from ground through the flame to the sense rod. The minimum flame current necessary to keep the system operating is 1.0 microamperes.

SINGLE SPARK AND SENSE

Figure 3a

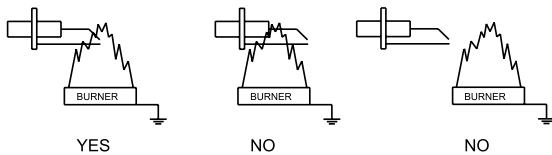

REMOTE FLAME SENSE

Figure 3b

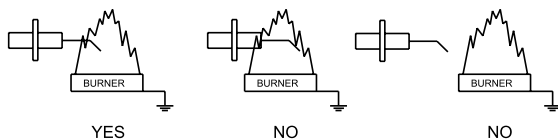

FLAME CURRENT CHECK: SINGLE SPARK & SENSE AND REMOTE SENSE

To measure flame current, disconnect the input voltage, and attach the leads from a DC current meter with a microampere range to FC+ and FC- terminals to the 35-70 flame sense test pins per Figure 4. Reconnect the input voltage and initiate a call for heat. After sparking is complete and the flame is established the meter should read 1.0 microamperes DC or higher. If meter reads below "0" on the scale, meter leads are reversed. Disconnect power and reconnect meter leads for proper polarity.

Figure 4

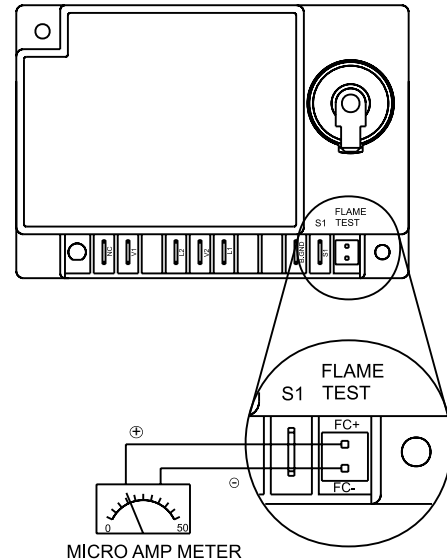

TYPICAL SPARK ELECTRODE WITH INTEGRAL REMOTE FLAME SENSE

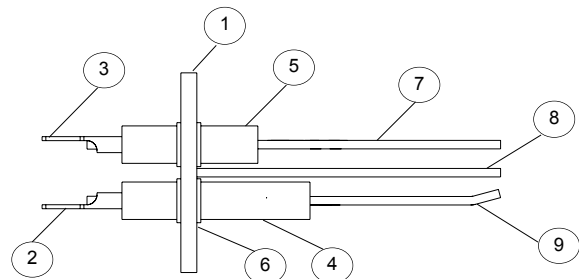

ITEM #	DESCRIPTION	STANDARD MATERIAL CSA rated at 1800°F	HIGH TEMP MATERIAL CSA rated at 2500°F
1	Mounting Bracket	Steel Cu Flashed	Steel Cu Flashed
2	1/4" Q.C. High Voltage Terminal	Nickel Plated Steel	Nickel Plated Steel
3	3/16" Q.C. Flame Sense Terminal	Nickel Plated Steel	Nickel Plated Steel
4	Spark, H.V. Ceramic Tube	L-3 Steatite	Alumina
5	Sense Electrode Ceramic Tube	L-3 Steatite	Alumina
6	Press Ring	Spring Steel	Spring Steel
7	Flame Sense Electrode	Kanthal D	Kanthal APM
8	Ground Rod	Kanthal D	Kanthal APM
9	Spark Electrode, High Voltage	Kanthal D	Kanthal APM

Electrode Assemblies

With over 1,000 configurations of spark electrodes and flame sense rods, Fenwal has a design for almost any application. The latest state-of-the-art wire forming and assembly equipment is used to accurately and efficiently produce high quality electrodes that deliver the hottest spark. The "Universal" electrodes depicted below are just a sampling of the 1,000 electrode styles available. These electrodes are designed for on-site customization. Cut and bend these to fit your application and then send the formed electrode back for Fenwal to detail *or* send us a print and we will provide you with a quote and samples.

SINGLE SPARK AND SENSE WITH INTEGRAL FLAME SENSE ELECTRODES

Part Number: 22-100000-593

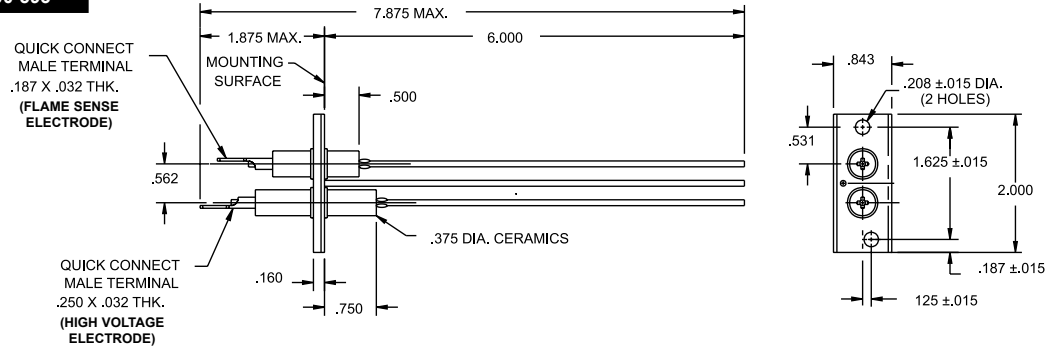

Part Number: 22-100001-076

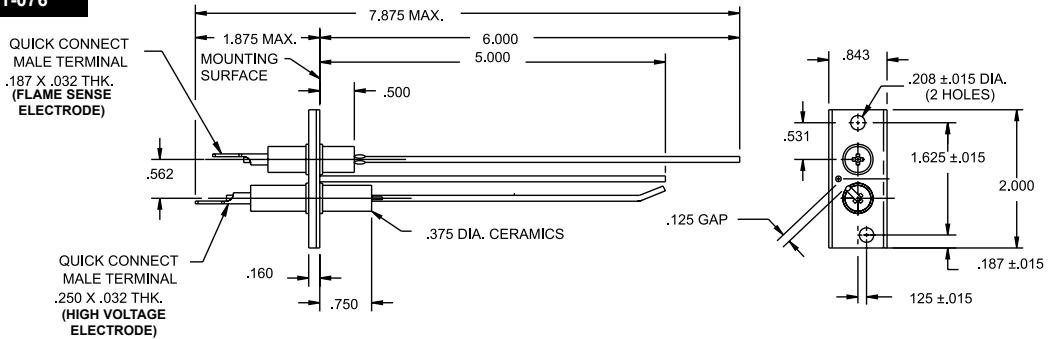

SINGLE SPARK AND SENSE ELECTRODES

Part Number: 22-100001-117

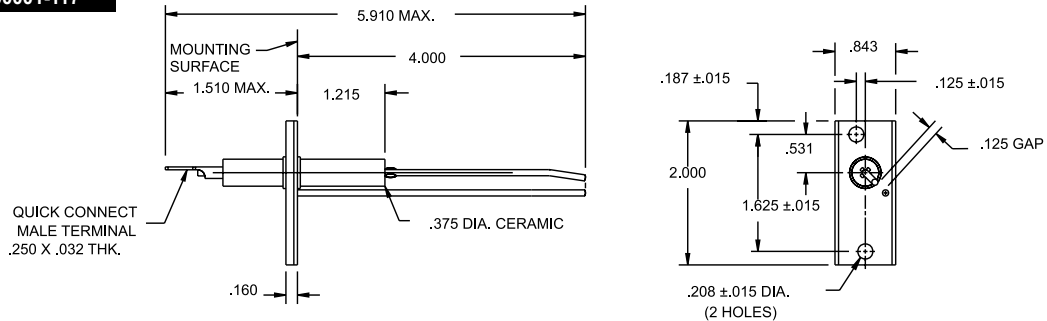

Part Number: 22-100001-052

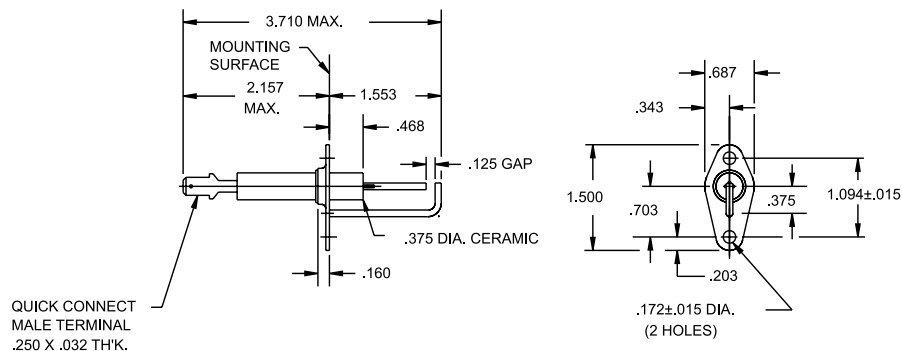

Electrode Assemblies *continued*

REMOTE FLAME SENSE ELECTRODES

Part Number: 22-100001-080

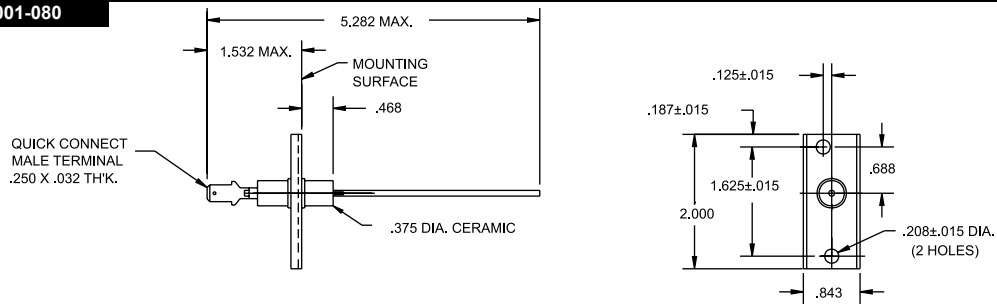

Part Number: 22-100001-110

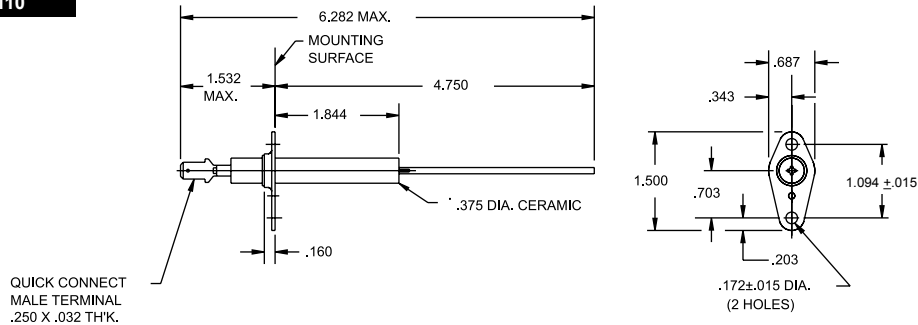

Control Wire Harness

Select the proper harness (6 or 7 PIN) based on flame sense choice. Once the terminal configuration is determined, complete the part number by replacing the last two digits ("XX") with the length in inches ("L" dimension). Standard wire lengths are 12, 18, 24, 30, 36, 48, and 60 inches. Example: 05-129892-118 = 18 inches. For other lengths, please contact Fenwal.

SPECIFICATIONS:	Voltage Rating	Agency Rating	Temperature Rating	Diameter	Jacket Material
All Wires	600 V	UL/CSA Listed	105°C (221°F)	18 gage stranded	PVC
Gray Only	600 V	UL/CSA Listed	200°C (392°F)	18 gage stranded	PVC

SINGLE SPARK SENSE

Part Number: 05-129864-8XX

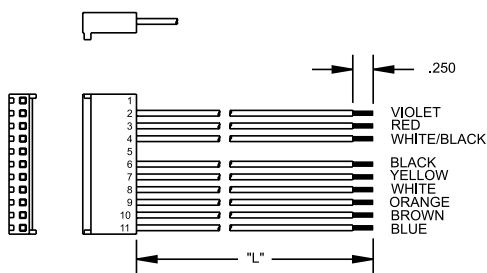

Part Number: 05-129864-7XX

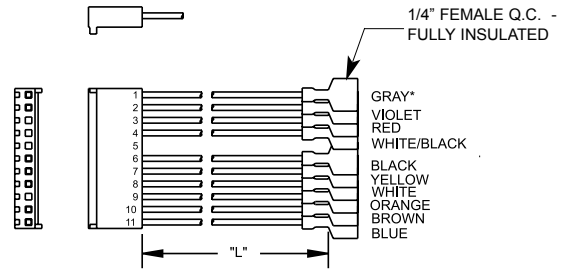

To make your own harness select AMP connector housing P/N: 1-770849-1 and AMP housing terminal P/N: 770522-1

REMOTE SENSE

Part Number: 05-129864-4XX

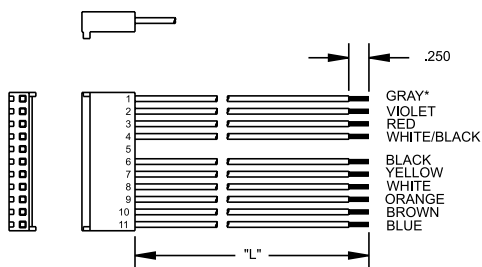

Part Number: 05-129864-3XX

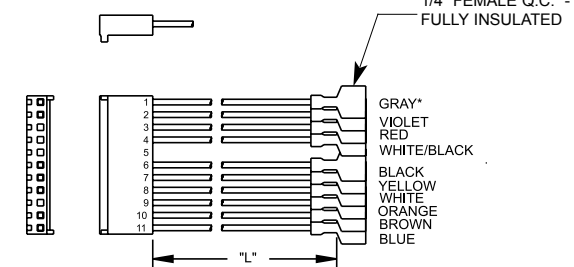

To make your own harness select AMP connector housing P/N: 1-770849-1 and AMP housing terminal P/N: 770522-1

High Voltage Ignition Wire - 3 Types

Delivering the 15K to 25K volts of spark energy from the ignition control to the electrode is a vital element of an ignition system. There are 3 material options and multiple terminal configurations available. Shown are the most popular versions offered by Fenwal. To ensure maximum spark energy, it is recommended that the ignition wires not be longer than 36". Longer lengths are available and should be evaluated on the appliance to determine if there is sufficient spark energy to consistently light the burner under all conditions. Once the wire type and terminal configurations are determined, complete the part number by replacing the last two digits ("XX") with the length in inches ("L" dimension). Standard wire lengths are 12, 18, 24, 30, 36, 48 and 60 inches. Example: 05-129608-018 = 18 inches. For other lengths, please contact Fenwal.

1. SILICONE RUBBER SUPPRESSION TYPE: Resistive carbon coated fiberglass core prevents spark energy radiation from interfering with other electronic systems. Select this wire type for applications where wire lengths are less than 36" and noise is a major concern.

SPECIFICATIONS: Voltage Rating 25 KVDC Agency Rating SAE J2031 Temperature Rating 200°C (392°F) Diameter 7mm (.27") Jacket Material Silicone Rubber over Fiberglass Braid

Part Number: 05-129608-0XX

Part Number: 05-129608-2XX

Part Number: 05-129608-6XX

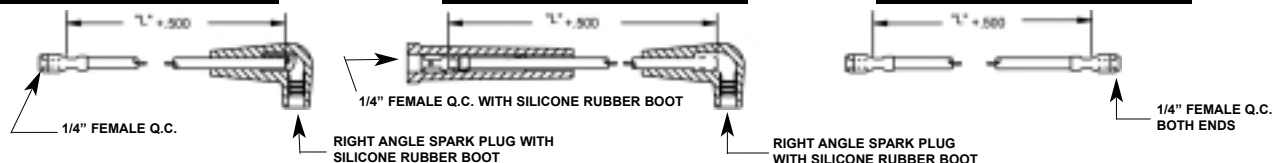

2. SILICONE RUBBER COPPER CONDUCTOR TYPE: Low resistance copper conductor transmits maximum spark energy. Select this type when maximum energy or longer wire lengths are required and noise is not a major concern.

SPECIFICATIONS: Voltage Rating 25 KVDC Agency Rating UL Type 3257 Temperature Rating 250°C (482°F) Diameter 7mm (.27") Jacket Material Silicone Rubber

Part Number: 05-127613-2XX

Part Number: 05-129865-0XX

Part Number: 05-125948-0XX



TERMINATIONS SAME AS TYPE 1

3. TEFLON INSULATED TYPE: Low resistance copper conductor transmits maximum spark energy. Select this type for applications that have tight clearances and sharp bend radii.

SPECIFICATIONS: Voltage Rating 25 KVDC Agency Rating UL Type 1911 Temperature Rating 250°C (482°F) Diameter 2mm (.08") Jacket Material Teflon

Part Number: 05-129887-0XX

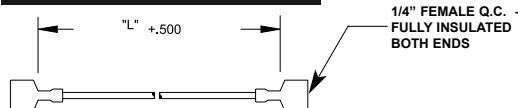

4. FLAME SENSE WIRES: Spark electrodes with integral remote sense rod, i.e. 22-100001-076, have a 3/16" male q.c.. Please choose flame sense wire 05-129866-0XX. For remote flame sense rods, i.e. 22-100001-080, choose flame sense wire part number 05-129866-1XX.

SPECIFICATIONS: Voltage Rating 600 V Agency Rating UL/CSA Listed Temperature Rating 200°C (392°F) Diameter 18 gage stranded Jacket Material PVC

Part Number: 05-129866-0XX

Part Number: 05-129866-1XX

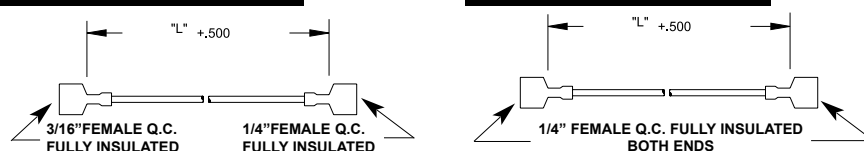

HOW TO ORDER

35 - 71 5 XXX - XXX

Enclosure Configurations and Wiring Options

- 2 = Potted Multi-Pin Connector (Figure 4)
- 3 = Case and Cover Multi-Pin Connector (Figure 6)
- 4 = Integral Stand-off's Multi-Pin Connector (Figure 5)
- 5 = Case and Cover Quick Connect (Figure 3)
- 6 = Integral Stand-off's Quick Connect (Figure 2)
- 7 = Potted Quick Connect (Figure 1)

OR

Assemblies

- 8 = Assemblies (may consist of control, high voltage ignition wire, electrode and harness)

OR

Non-Standard Configurations

9 = Non Standard Configuration
 A 9 in this location of the part number (i.e. 35-725 901-113) identifies this configuration as a non-standard design. The part number does not follow the part numbering system. The 9XX is a sequential part number assigned by Fenwal. Consult factory for operating characteristics of this control.

Combustion Blower Control, Post-purge time and Power Options

- 0 = 0 second post-purge and no full-time power requires single 120 VAC input for both blower and thermostat/ control device
- 1 = 0 second post purge with full-time power requires individual 120VAC inputs for blower and the thermostat which allows higher current to feed the combustion blower without having the high current pass through the thermostat
- 2 = 30 second post purge with full-time power
- 3 = 60 second post purge with full-time power

Trial for Ignition Time (TFI)

- 1 = 4 seconds
- 3 = 7 seconds
- 5 = 10 seconds
- 7 = 15 seconds

Inter-Purge Time

- 0 = None
- 1 = 15 seconds
- 2 = 30 seconds

Pre-Purge Time

- 0 = None
- 1 = 15 seconds
- 2 = 30 seconds
- 5 = 5 seconds

Number of Ignition Trials, Flame Sense Method and Lock Out Reset Method

- 0 = 1 try, single spark and sense Thermostat / power off reset
- 1 = 1 try, remote sense Thermostat / power off reset
- 2 = 1 try, single spark and sense Automatic reset
- 3 = 1 try, remote sense Automatic reset
- 5 = 3 try, single spark and sense Thermostat / power off reset
- 6 = 3 try, remote sense Thermostat / power off reset
- 7 = 3 try, single spark and sense Automatic reset
- 8 = 3 try, remote sense Automatic reset



MOST COMMON CONFIGURATIONS

Fenwal offers any option variation listed in the above part number scheme along with customized configurations to meet your exact application requirements. Because of the numerous options available, models not listed in the table below are made to order. For quick-ship samples and quick-ship orders, please select a model from the table below. *All controls listed below are Full Time Power Models.*

Ignition Control Part Number	Enclosure Type			Wiring		Post Purge			Number of Ignition Trials		Flame Sense Method		Lockout Reset Method		Pre-purge Time (seconds)				Inter-purge Time (seconds)			Trial for Ignition Time (seconds)			
	Stand Off	Case	Potted	Q.C.	Multi-Pin	0	30	60	1	3	Single	Remote	Thermostat/ Power - off	Auto	0	15	30	5	0	15	30	4	7	10	15
35-715510-505	
35-715325-113	
35-715526-113	
35-715331-503	
35-715725-113		
35-715226-113		

POTTED

Figure 1

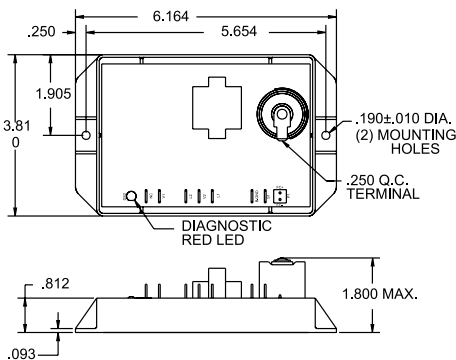
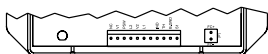

Figure 4



INTEGRAL STAND-OFF

Figure 2

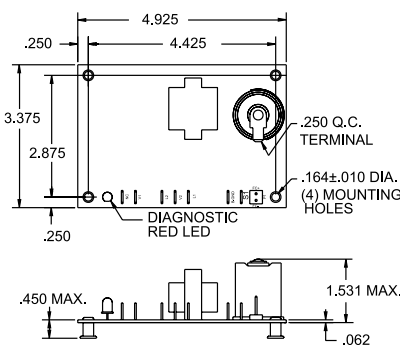
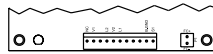

Figure 5



CASE AND COVER

Figure 3

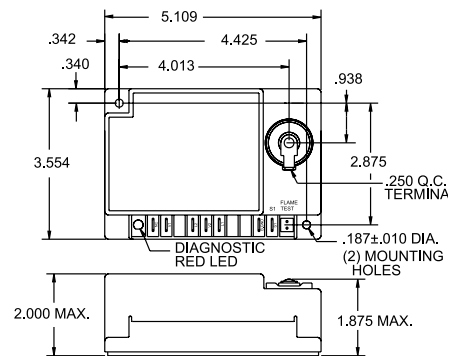

Figure 6



400 MAIN STREET, ASHLAND, MA 01721
 TEL: (508) 881-2000
 FAX: (508) 881-6729
 www.fenwalcontrols.com

These instructions do not purport to cover all the details or variations in the equipment described, nor do they provide for every possible contingency to be met in connection with installation, operation and maintenance. All specifications subject to change without notice. Should further information be desired or should particular problems arise which are not covered sufficiently for the purchaser's purposes, the matter should be referred to KIDDE-FENWAL, Inc., Ashland, Massachusetts.



© 2003 Kidde-Fenwal, Inc. Printed in U.S.A. TAG

P/N 35-71-02 6/20/03