



120 VAC Microprocessor Based Hot Surface Ignition Control

35.75.02

FEATURES

- Safe Start - verifies no flame is present and proper control function before heat sequence begins
- Use with variety of 120 VAC hot surface ignitors up to 5 Amps
- Two Mounting Configurations
 - Open Board with Stand-Off's - saves space and cost
 - Potted - protection for washdown and vibration
- Multi Pin Connector - fast assembly
- 2 Trial for Ignition Options - 1 and 3 try
- 4 Trial for Ignition Times - 4, 7, 10 and 15 seconds (customized timings available)
- 2 Flame Sense Options - local or remote sense
- Automatic One Hour Reset Option
- Flame current test pins - facilitates field service



APPLICATIONS

- Tube heaters
- Construction heaters
- Commercial cookers
- Any 120 VAC gas burner application under 400K BTU

The Series 35-75 controls are designed to perform many gas-fired 120 VAC appliance functions in a single control resulting in lower system cost. The Series 35-75 monitors the demand for heat, ignites and monitors the flame during heating.

The microprocessor circuit design provides precise, repeatable timing sequences for ignition times and purge times as well as multiple tries for ignition. The control will accommodate a variety of ignitor models up to 5 Amps.

Agency Certifications

 Design certified by CSA International to CAN C22.2 #199-M89 and ANSI Z21.20 for Automatic Ignition Systems, including UL1998 software review.

SPECIFICATIONS

Input Power Voltage	Control: 102 to 138 VAC 50/60 Hz (Class 2 Transformer)
	Line: 120 VAC
Current	Current: 100 mA max. @ 120 VAC at 25°C (Control only)
Output (Contact Ratings)	Gas Valve: 1.5 A max. @ 120 VAC
	Hot Surface Element: 5.0 A max. @ 120 VAC
Operating Temperatures	-40°F to +176°F (-40°C to +80°C)
Flame Sense Voltage	50% of line voltage minimum
Flame Sensitivity	1.0 mA minimum
Types of Gas	Natural, LP, or manufactured
Ignitor	120 VAC hot surface ignitors up to 5 A
Moisture Resistance	Open Board: Conformal coated to operate non-condensing to 95% R.H. Care must be taken to protect module from direct exposure to water
	Potted: To operate up to 100% R.H
Size (LxWxH)	See Figures 2a or 2b
Weight	Open Board: 2.3 oz
	Potted: 6.1 oz

SEQUENCE OF OPERATION / FLAME RECOVERY/ SAFETY LOCKOUT

Power-Up

Upon applying power (120 volts), the control will reset, perform a self-check routine, monitor the flame sense input to verify no flame is present and enter the thermostat scan state.

Call for Heat

When a call for heat is received from the thermostat supplying 120 volts to the TH terminal, the control will perform a self-check routine, the safety timing sequence and flame check. After an optional "pre-purge" period, the hot surface ignitor is energized for a heat-up period, followed by the gas valve for the "trial for ignition" (TFI) period. If flame is detected during purge, the gas valve will remain de-energized.

Ignition

When a valid flame is detected during the TFI period, the ignitor is de-activated and the gas valve remains energized. The thermostat and main burner flame are constantly monitored to assure that the system operates properly. The control will continuously monitor the flame during the heating period. (If flame is lost, the gas valve will be shut off within 0.8 seconds.) When the thermostat is satisfied and the demand for heat ends, the gas valve is de-energized immediately.

System Failure During Trial-for-Ignition Period

The robust design of our gas ignition controls is demonstrated by their ability to respond to flame failures in a safe manner and provide re-ignition options for the appliance designer.

Flame Failure During Trial-for-Ignition Period

SINGLE TRIAL MODEL

Should the main burner fail to light or the flame is not detected during the TFI, the control will lockout. The gas valve will be turned off immediately. With the 1 hour reset option, if the thermostat is still calling for heat, the control will auto-matically reset and attempt a new TFI after one hour.

MULTI TRIAL MODEL

Should the main burner fail to light or the flame is not detected during the first TFI, the gas valve is de-energized and the control performs an optional "inter-purge" delay before attempting another TFI. The control will attempt 2 additional TFI's before locking out. In lockout, the gas valve will be turned off immediately. With the 1 hour reset option, if the thermostat is still calling for heat, the control will automatically reset and attempt a new TFI after one hour.

Flame Failure of Established Flame

RE-IGNITION

If the established flame signal is lost while the burner is operating, the control will respond within 0.8 seconds and de-energize the gas valve. The control performs an optional "inter-purge" delay before attempting a new TFI. If the burner does not re-light, the control will lockout as previously described in the "Failure to Light - Lockout" section. Multi-try models will make 2 more attempts to light the burner. If flame is re-established, normal operation resumes.

Lockout Mode (On-Board Safety System)

After single or multiple attempts to light the burner have failed or flame is not established, the control automatically enters lockout mode. The control will not open the gas valve unless there is intervention by the user. See Lockout Recovery.

Lockout Recovery

Recovery from lockout requires a manual reset by either resetting the thermostat or by removing the 120 volts for a period of 5 seconds.

TROUBLESHOOTING GUIDE

Table 1

Symptom	Recommended Actions
1. Does not start	A. Check wiring B. No voltage at PIN 3, check thermostat C. Fuse/circuit breaker bad D. Bad control, consult factory
2. Thermostat on - no ignition	A. Check wiring B. Bad thermostat, no voltage at thermostat terminal TH C. Failed ignitor
3. Valve on - no ignitor	A. Check wiring B. Defective ignitor C. Bad control, check voltage at ignitor
4. Ignitor on - no valve	A. Valve coil open B. Open valve wire C. Bad control, check voltage at gas valve terminal
5. Flame okay during TFI - no flame sense after TFI	A. Bad ignitor B. Bad S1 wire C. Poor ground at burner D. Poor flame, check flame current



WARNING: Operation outside specifications could result in failure of the Fenwal product and other equipment with injury or death to people and damage to property. Service to this product should only be performed by a qualified technician.

MOUNTING AND WIRING

The 35-75 is not position sensitive and can be mounted vertically or horizontally. The control may be mounted on any surface and fastened with #6 sheet metal screws. Secure the control in an area that will experience a minimum of vibration and remain below the maximum ambient temperature of 80°C (176°F). All connections should be made with UL approved, 105°C (221°F) rated 18 gauge stranded wire with .054" minimum insulation. Refer to Figures 1a & 1b Wiring Diagram when connecting the control to other components in the system.

Wiring Diagrams

LOCAL SENSE

Figure 1a

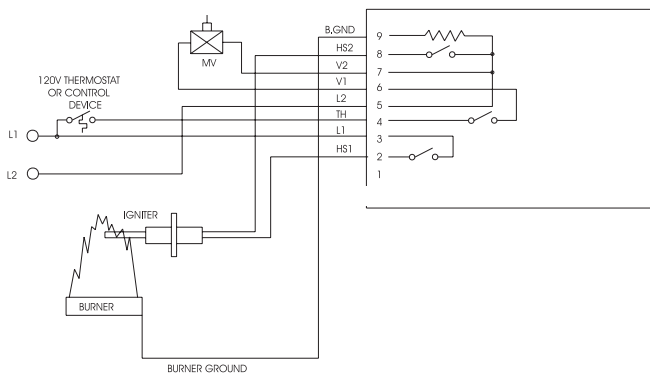

REMOTE SENSE

Figure 1b

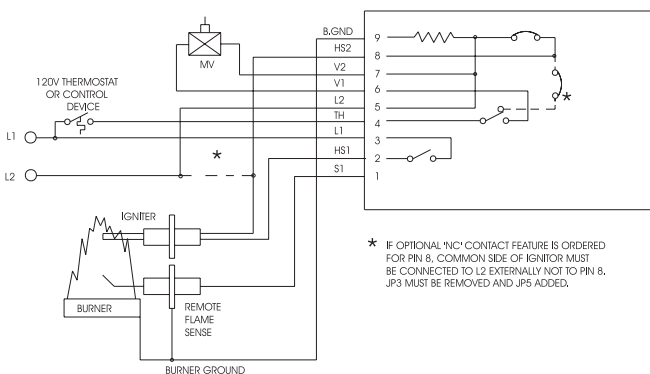

Terminal Designations

Table 2

TERMINAL	PIN LOCATION	DESCRIPTION	WIRE COLOR
S1	1	Remote Sense	ORANGE
HS1	2	Ignitor Power	GRAY
L1	3	120VAC Input (Hot) (Full Time Power)	RED
TH	4	Thermostat	BLACK
L2	5	Neutral	WHITE
V1	6	Valve Power	BROWN
V2	7	Valve Neutral	YELLOW
HS2	8	Ignitor Return (or NC Contact)	BLUE
B.GND	9	Burner Ground	GREEN
FC+ & FC		Flame Current Test Pins	-

WARNING:
Operation outside specifications could result in failure of the Fenwal product and other equipment with injury or death to people and damage to property. Service to this product should only be performed by a qualified technician.

CAUTION:
Label all wires prior to disconnection when servicing the control. Wiring errors can cause improper and dangerous operation. A functional checkout of a replacement is required.

DIMENSIONS

OPEN BOARD WITH STANDOFFS

Figure 2a

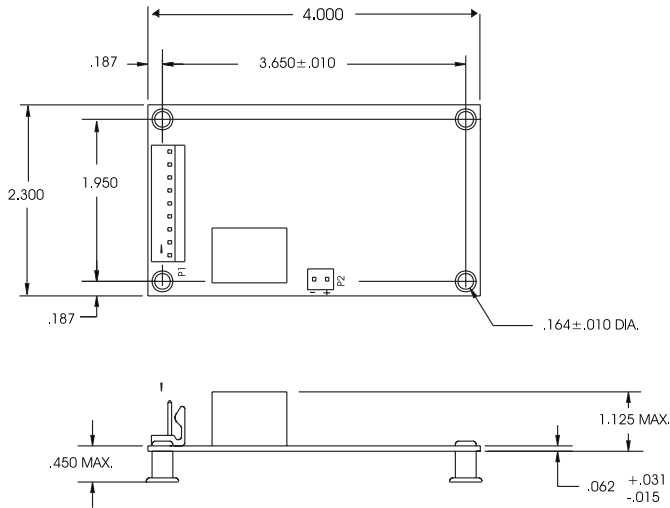

POTTED

Figure 2b

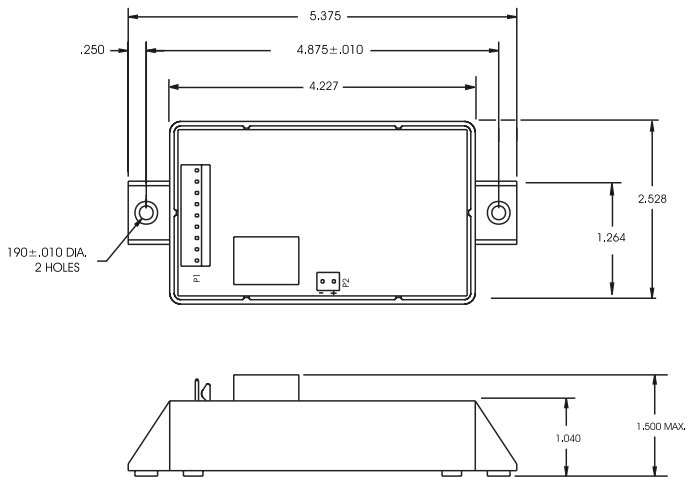

HOT SURFACE IGNITOR

Proper location of the hot surface ignitor is important to achieve optimum system performance for both ignition and flame sensing. See Figures 3 and 4.

NOTE: The temperature of the ceramic holder should not exceed the manufacturer's specifications.

Figure 3

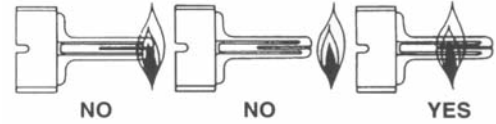

TYPICAL HOT SURFACE IGNITOR

Figure 4

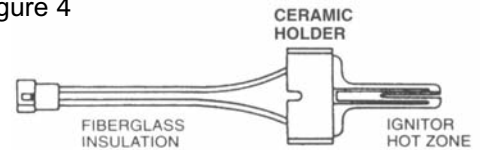

WARNING:

Operation outside specifications could result in failure of the Fenwal product and other equipment with injury or death to people and damage to property. Service to this product should only be performed by a qualified technician.

FLAME SENSOR CURRENT CHECK

Figure 5

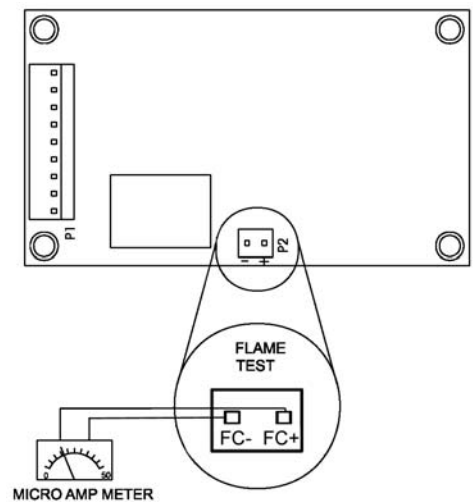

Flame current is the current that passes through the flame from the sensor to ground. The minimum flame current necessary to keep the system from lockout is 1.0 microamps. To measure flame current, connect an analog DC microammeter to the FC terminals per Figure 5. Meter should read 1.0 mA or higher. If meter reads below "0" on scale, meter leads are reversed. Disconnect power and reconnect meter leads for proper polarity.

CONTROL WIRE HARNESS

Select the proper harness based on the 35-75 control's termination connection. Once the terminal configuration is determined, complete the part number by replacing the last two digits ("XX") with the length in inches ("I" dimension). Standard wire lengths are 12, 18, 24, 30, 36 and 48 inches. Example 05-129921-024 = 24 inches. For other lengths, please contact Fenwal.

SPECIFICATIONS:	<u>Voltage Rating</u>	<u>Temperature Rating</u>	<u>Diameter</u>	<u>Jacket Material</u>	<u>Agency Listings</u>
	600 V	105°C (221°F)	18 AWG stranded	PVC	UL/CSA

9 POSITION REMOTE OR LOCAL SENSE HARNESS

Part Number: 05-129921-1XX

Figure 6:

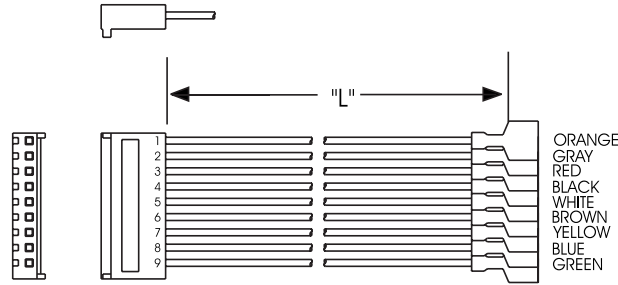

To make a harness select Amp connector housing Part Number 770849-9 and Amp housing terminal Part Number 770552-1

XX = Wire length in inches

REMOTE FLAME SENSE

REMOTE FLAME SENSE RODS

Part Number: 22-100001-080

Figure 7:

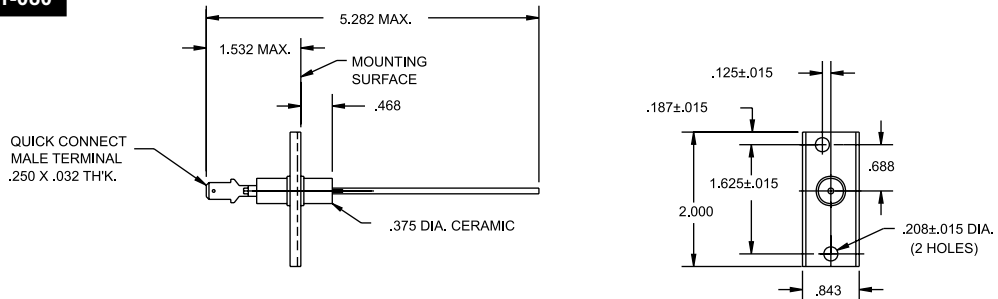

Part Number: 22-100001-110

Figure 8:

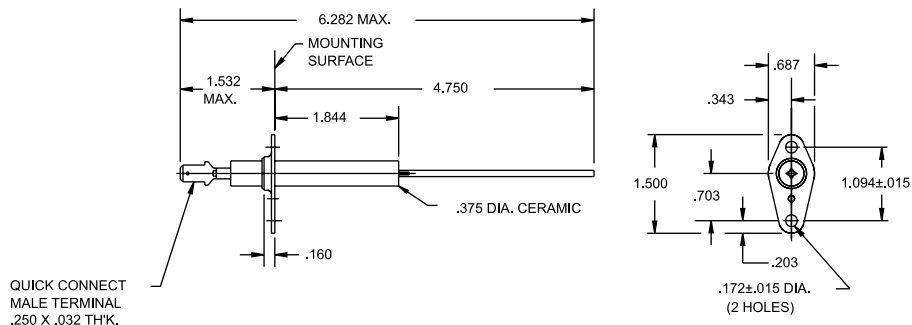

CONTROL CONFIGURATION

35 - 7 5 5 X X X - X X X DESCRIPTION

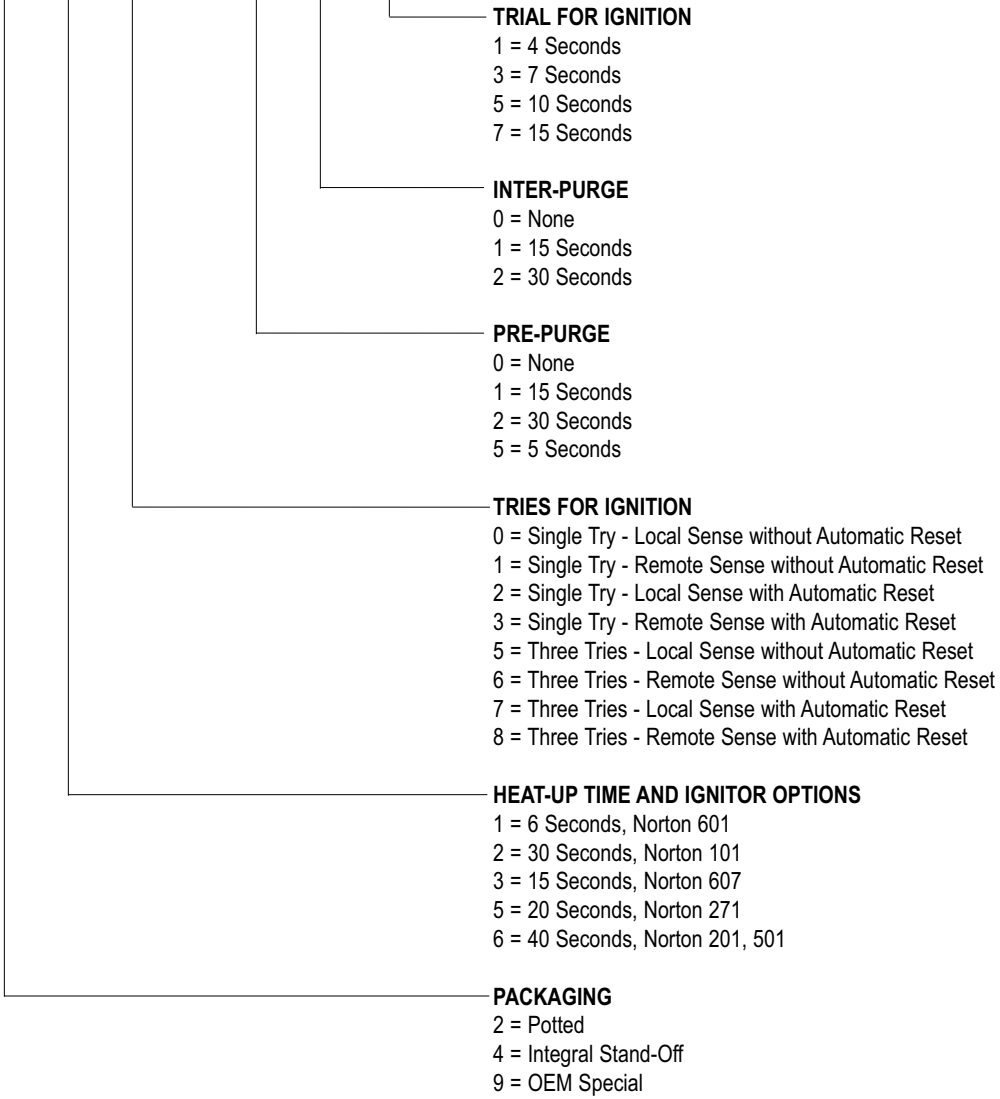

800-536-1582 Fax: 866-448-9304
info@parts4heating.com



FENWAL
 400 MAIN STREET, ASHLAND, MA 01721
 TEL: (508) 881-2000 FAX: (508) 881-6729
www.fenwalcontrols.com

These instructions do not purport to cover all the details or variations in the equipment described, nor do they provide for every possible contingency to be met in connection with installation, operation and maintenance. All specifications subject to change without notice. Should further information be desired or should particular problems arise which are not covered sufficiently for the purchaser's purposes, the matter should be referred to KIDDE-FENWAL, Inc., Ashland, Massachusetts.