

POWERED DIRECT VENT SERIES GAS-FIRED COMMERCIAL WATER HEATER (INDEPENDENT PVC VENTING)

A Spanish language version of these instructions is available by contacting the company listed on the rating plate.

La versión española de estas instrucciones se puede obtener al escribirle a la fábrica cuyo nombre aparece en la placa de especificaciones.

INSTALLATION AND OPERATING INSTRUCTION MANUAL

parts4heating
800-536-1582 Fax: 866-448-9304
info@parts4heating.com

WARNING: If the information in these instructions is not followed exactly, a fire or explosion may result causing property damage, personal injury or death.

FOR YOUR SAFETY

- Do not store or use gasoline or other flammable, combustible, or corrosive vapors and liquids in the vicinity of this or any other appliance.

- WHAT TO DO IF YOU SMELL GAS

- Do not try to light any appliance.
- Do not touch any electrical switch; do not use any phone in your building.
- Immediately call your gas supplier from a neighbor's phone. Follow the gas supplier's instructions.
- If you cannot reach your gas supplier, call the fire department.

- Installation and service must be performed by a qualified installer, service agency or the gas supplier.

For your safety and convenience, we recommend this water heater be installed and serviced by a plumbing professional.

TABLE OF CONTENTS

	Page
GENERAL INFORMATION.....	3
INSTALLATION.....	5
Locating The Water Heater.....	5
Minimum Clearances.....	8
Venting.....	10
Venting Lengths (150,000 and 199,999 Btu/hr. Models).....	12
Direct Vent System Installation	14
Venting Requirements for Models Over 200,000 Btu/hr. ...	20
Water Connections.....	21
Gas Connections	25
Electrical Connections.....	26
Wiring Diagram	27
Illustration of Typical Water Heater Installation.....	28
GENERAL OPERATION.....	29
Lighting and Shutdown Instructions.....	30
Temperature Adjustment.....	31
Burner Flame Check.....	33
MAINTENANCE	35
OPERATING & TROUBLESHOOTING GUIDE.....	40
TEMPERATURE CONTROL SERVICING PROCEDURE.....	49
WATER HEATER PARTS LIST DRAWING.....	50
WATER HEATER PARTS LIST	51
INSTALLATION INSTRUCTIONS FOR POTABLE WATER AND SPACE HEATING	53
NOTES.....	55

GENERAL INFORMATION

This gas-fired water heater is design certified by CSA International under the American National Standard, Z21.10.3 (as indicated on the rating plate) and CAN/CGA 4.3-M- (as indicated on the rating plate) available from CSA Standards Association, 178 Rexdale Blvd., Etobicoke, Ontario, Canada M9W 1R3.

This water heater must be installed in accordance with local codes. In the absence of local codes, it must be installed in compliance with the National Fuel Gas Code (ANSI Z223.1-Latest Edition), or in Canada CAN/CGA B149.1 Natural Gas Installation Code (Latest Edition) or CAN/CGA B149.2 Propane Installation Code (Latest Edition).

This water heater has been equipped for use with **one type of gas only**. Compare the information provided on the rating plate, affixed to the front of the water heater, making sure that the gas stated on the rating plate is the same as the gas to be used.

▲ CAUTION

Do not attempt to use this water heater with any gas other than the type listed on the rating plate. Do not attempt to convert this water heater for use with a gas other than the type for which it is equipped. Failure to use the proper gas can create an unsafe condition resulting in property damage, bodily injury, or death. Consult your local gas supplier or gas company if there are any questions.

The warranty for this water heater is in effect only when the water heater is installed, adjusted, and operated in accordance with these Installation and Operating Instructions. The warranty does not cover damage or injury caused by the use of any energy-saving devices (other than those authorized by the manufacturer) in conjunction with this water heater. The use of unauthorized energy-saving devices may decrease the life of the water heater and endanger life and/or property. The manufacturer will not be liable for any damage, injury, or loss of life resulting from alteration and/or failure to comply with these instructions.

For installations in high altitude regions, this water heater must be ordered from the supplier to the manufacturer's specifications for that particular altitude. Contact the company listed on the rating plate when ordering water heaters for high altitude installations.

General Information continued-

This water heater has been designed and certified for the purpose of heating potable water. The installation and use of this water heater for any purpose other than the heating of potable water may cause damage to the water heater, create a hazardous condition, and nullify the warranty.

▲ CAUTION

Incorrect operation of this appliance may create a hazard to life and property and will nullify the warranty.

▲ DANGER

Do not store or use gasoline or other flammable, combustible, or corrosive vapors and/or liquids in the vicinity of this or any other appliance.

IMPORTANT

Before proceeding, please inspect the water heater and venting components for possible damage. **DO NOT** install damaged components. If damage is evident then please contact the supplier where the water heater was purchased or the manufacturer listed on the rating plate for replacement parts.

Sacrificial anode rods are used to extend tank life. In areas where water is unusually active, an odor may occur at the hot water faucet due to a reaction between the sacrificial anode and the impurities in the water. **This is not the fault of the water heater.** If this should happen, alternative aluminum anode rods may be purchased from the supplier of this water heater or the manufacturer. This will minimize odor while protecting the tank. Additionally, the water heater should be flushed with appropriate dissolvers to eliminate any bacteria. **The removal of the anode rods will void the warranty.**

INSTALLATION

Locating The Water Heater

▲WARNING

Water heaters are heat-producing appliances. To avoid damage or injury there must be no materials stored against the water heater and proper care must be taken to avoid unnecessary contact (especially by children) with the water heater components. **UNDER NO CIRCUMSTANCES SHALL FLAMMABLE MATERIALS, SUCH AS GASOLINE OR PAINT THINNER BE USED OR STORED IN THE VICINITY OF THIS WATER HEATER, DIRECT VENT SYSTEM OR IN ANY LOCATION FROM WHICH FUMES COULD REACH THE WATER HEATER OR DIRECT VENT SYSTEM.**

This water heater must NOT be installed in any location where gasoline or flammable vapors are likely to be present.

The location of this water heater is of the utmost importance. Before installing this water heater, you should read the Installation section of these instructions. After reading these Installation and Operating Instructions, select a location for the water heater where the floor is level and is easily accessible to water lines, gas supply (type identified on the rating plate), an adequate open drain, and within the maximum specified venting distance to an outside wall or roof for the direct vent terminal. **DO NOT locate the water heater where water lines could be subjected to freezing temperatures. Make sure the cold water pipes are not located directly above the gas control so that condensate during humid weather does not drip or accumulate on the controls.**

Adequate clearances must be provided for easy access to controls by service personnel to enable proper cleaning, servicing, and operation of the water heater. Under no circumstances is the front of the water heater to be placed in a position where the burner tray assembly cannot slide out for removal when servicing.

▲WARNING

DO NOT ATTEMPT TO LIGHT ANY GAS APPLIANCE IF YOU ARE NOT CERTAIN OF THE FOLLOWING:

- Liquefied petroleum gases/propane gas and natural gas have an odorant added by the gas supplier that aids in detection of the gas.
- Most people recognize this odor as a "sulfur" or "rotten egg" smell.
- Other conditions, such as "odorant fade" can cause the odorant to diminish in intensity, or "fade", and not be as readily detectable.
- If you have a diminished sense of smell, or are in any way unsure of the presence of gas, immediately contact your gas supplier from a telephone in another building.
- Gas detectors are available. Contact your gas supplier or plumbing professional for more information.

Proper venting practices must be considered when selecting a location for this water heater. For exact venting specifications, please consult the Venting section of these Installation and Operating Instructions.

This water heater must be located in an area where leakage of the tank, water line connections, or the combination temperature and pressure relief valve will not result in damage to the area adjacent to the water heater or to lower floors of the structure. When such locations cannot be avoided, a suitable drain pan must be installed under the water heater. The drain pan depth must be suitable for draining and collecting water, but must not interfere with access for servicing the burner compartment and have a minimum length and width of at least four (4) inches (10.2 cm) measured from the jacket of the water heater. The drain pan, as described above, can be purchased from your plumbing professional. The drain pan must be piped to an adequate drain. The piping must be at least 3/4 inch (1.9 cm) in diameter and pitched for proper drainage.

It is recommended that a minimum clearance of four (4) inches (10.2 cm) be provided on the side of the water heater for servicing and maintenance of the combination temperature and pressure relief valve.

Water heater corrosion and component failure can be caused by the heating and breakdown of airborne chemical vapors. Examples of some typical compounds that are potentially corrosive are: spray can propellants, cleaning solvents, refrigerator and air conditioning refrigerants, swimming pool chemicals, calcium and sodium chloride, waxes and process chemicals.

These materials are corrosive at very low concentration levels with little or no odor to reveal their presence. **NOTE: DAMAGE TO THE WATER HEATER CAUSED BY EXPOSURE TO CORROSIVE VAPORS IS NOT COVERED BY THE WARRANTY. DO NOT OPERATE THE WATER HEATER IF EXPOSURE HAS OR WILL OCCUR. DO NOT STORE ANY POTENTIALLY CORROSIVE COMPOUNDS IN THE VICINITY OF THE WATER HEATER OR THE DIRECT VENT TERMINAL.**

▲WARNING

Liquefied petroleum gases/propane gas is heavier than air and will remain at floor level if there is a leak. Basements, crawl spaces, closets and areas below ground level will serve as pockets for accumulation of leaking gas. Before lighting, smell all around the appliance area for gas. Be sure to smell next to the floor.

IF YOU SMELL GAS:

- Do not try to light any appliance.
- Do not touch any electric switch; do not use any telephone in your building.
- Immediately call your gas supplier from a telephone in another building. Follow the gas supplier's instructions.
- If you cannot reach your gas supplier, call the fire department.

DO NOT OPERATE THE APPLIANCE UNTIL THE LEAKAGE IS CORRECTED!

Minimum Clearances

▲WARNING

Failure to adhere to these installation and operating instructions may create a hazard to life and property and will nullify the warranty.

This installation must allow access to the front of the water heater and adequate clearance must be provided for servicing and operating this water heater. The water heater may be installed on either a combustible or non-combustible floor. If the installation is on carpeting, the water heater must be installed on top of a metal or wood panel (or equivalent) extending beyond the full width and depth of the appliance by at least three (3) inches (7.6 cm) in any direction. The panel must cover the entire floor if the water heater is to be installed in a carpeted alcove or closet. The panel must be strong enough to support the weight of the water heater when full of water.

The minimum clearances to combustibles for this water heater are: two (2) inches (5.1 cm) from the sides and rear, sixteen (16) inches (40.6 cm) from the top jacket, zero (0) inch (0 cm) from the air intake boot and vent tubes and twelve (12) inches (30.5 cm) in any direction from the vent terminal. A minimum of 30 inches front clearance from the burner access cover is necessary for inspection and servicing.

This water heater may be installed in an alcove on combustible flooring with clearances from combustible materials as shown in the tables listed in the Installation Minimum Clearances section of this Installation and Operating Instruction Manual.

▲CAUTION

The National Fuel Gas Code (ANSI Z233.1-or latest edition) and CAN/CGA (B149.1-or latest edition), expressly prohibits the installation of a water heater in a garage, unless the unit is installed so that the burner and ignition devices are at least eighteen (18) inches (46 cm) above floor level and protected to avoid damage by a moving vehicle.

Installation (Minimum Clearances) continued-

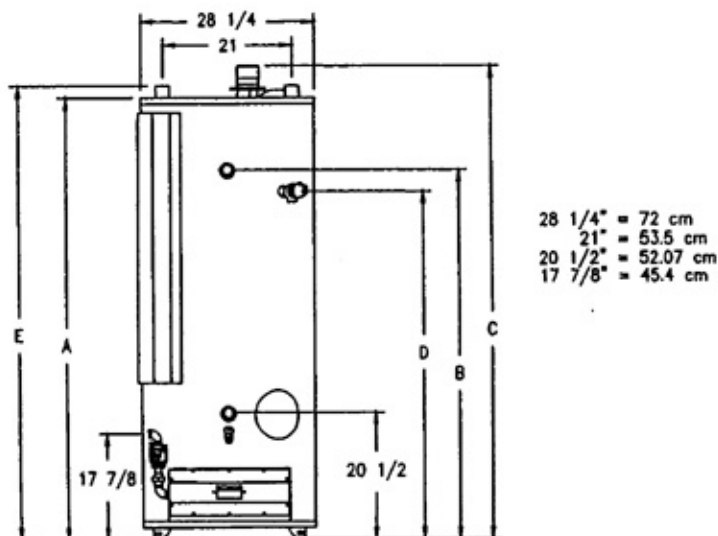

Figure 1

Model Description			Dimensions for Figure 1				
Capacity (Gal)	Input (BTU/hr)		A (in.)	B (in.)	C (in.)	D (in.)	E (in.)
	Net.	LP					
100	199,999	199,999	72.13	60.31	77.19	56.81	74.13
100	150,000	150,000	72.13	60.31	77.19	56.81	74.13
100	250,000	225,000	72.13	60.31	82.13	56.81	74.13
80	250,000	225,000	63.13	51.31	68.19	47.81	65.13
80	199,999	199,999	63.13	51.31	68.19	47.81	65.13
80	150,000	150,000	63.13	51.31	68.19	47.81	65.13

Model Description			Clearances		
Capacity (Gal)	Input (BTU/hr)		Sides and Rear (in.)	Flue or Vent (in.)	Ceiling (in.)
	Net.	LP			
100	199,999	199,999	2	0	16
100	150,000	150,000	2	0	16
100	250,000	225,000	2	0	16
80	250,000	225,000	2	0	16
80	199,999	199,999	2	0	16
80	150,000	150,000	2	0	16

Model Description			Dimensions for Figure 1				
Capacity (Liter)	Input (kW/hr)		A (Cm)	B (Cm)	C (Cm)	D (Cm)	E (Cm)
	Net.	LP					
378.5	58.6	58.6	183.2	153.2	196.1	144.3	188.3
378.5	43.9	43.9	183.2	153.2	196.1	144.3	188.3
378.5	73.2	65.9	183.2	153.2	208.4	144.3	188.3
302.8	73.2	65.9	160.4	130.3	173.2	121.4	165.4
302.8	58.6	58.6	160.4	130.3	173.2	121.4	165.4
302.8	43.9	43.9	160.4	130.3	173.2	121.4	165.4

Installation (Minimum Clearances) continued-

Model Description			Clearances		
Capacity (Liter)	Input (kW/hr)		Sides and Rear (Cm)	Flue or Vent (Cm)	Ceiling (Cm)
	Nat.	LP			
378.5	58.6	58.6	5.1	0	40.6
378.5	43.9	43.9	5.1	0	40.6
378.5	73.2	65.9	5.1	0	40.6
302.8	73.2	65.9	5.1	0	40.6
302.8	58.6	58.6	5.1	0	40.6
302.8	43.9	43.9	5.1	0	40.6

Venting

This water heater is a Powered Direct Vent Gas Water Heater where all air for combustion is obtained from the outside atmosphere and all flue gases are discharged to the outside atmosphere. The venting system consists of separate PVC combustion air intake and flue exhaust pipes. Venting may be run horizontally through an outside wall or vertically through a roof through 3" (7.6 cm) or 4" (10.2 cm) diameter PVC, ABS or CPVC pipe for models with input ratings under 200,000 Btu/hr. Models with input ratings over 200,000 Btu/hr. (check the model nameplate) must use 4" (10.2 cm) diameter PVC, ABS, or CPVC only. The water heater is supplied with a screened intake and exhaust 90° elbow referred to as the exhaust vent or combustion air intake terminal (see figure 4 on pg. 15). Consult the venting table in this section for the maximum venting distances with 3" (7.6 cm) and 4" (10.2 cm) PVC pipe. **Note: The combustion air intake must be piped to the outdoors as outlined in the following instructions in order for this appliance to be a direct vent water heater.**

WARNING

The direct vent system must be properly installed. Failure to properly install the direct vent system could result in property damage, personal injury, or death.

DO NOT install any damaged venting system components. If damage is evident then please contact the supplier where the water heater was purchased or the manufacturer listed on the rating plate for replacement parts.

Use only the vent terminals provided or factory authorized for venting this water heater.

Exhaust Vent and Combustion Air Intake Terminals (See Figure 2)

- Must terminate at least 3 ft. (0.9 m) above any forced air inlet located within 10 feet (3.1 m). This provision does not apply to the combustion air intake of a direct vent appliance or the circulating air inlet and flue gas discharge of listed outdoor appliances.

Installation (Venting) continued-

- The exhaust vent terminal must be installed with at least a 12 in. (30 cm) clearance from any air opening into a building.
- The bottom of the exhaust vent and combustion air intake terminals must be located at least 12 in. (30 cm) above grade and above the anticipated snow level.
- Must be installed at least 3 ft. (0.9 m) from any gas meter, gas valve or other gas regulating equipment.
- Must be installed in a location where it will not be blocked by snow.
- The exhaust vent and combustion air intake terminals must be installed so that the centerline distances are at least 6" (15.2 cm) apart and the exhaust vent terminal elbow extends 6" (15.2 cm) past the combustion air intake terminal. The two terminals must be installed on the same wall or roof section and cannot be more than 24" (61.0 cm) apart.

Note: Provide protection of the building materials from degradation by flue gases from the exhaust vent terminal.

Exceptions for Installations in Canada .

The vent terminal must not terminate:

- (a) directly above a paved sidewalk or paved driveway which is located between two single-family dwellings and serves both dwellings;
- (b) less than 7 ft (2.1 m) above a paved sidewalk or a paved driveway located on public property;
- (c) within 6 ft (1.8 m) of a mechanical **air supply** inlet to any **building**;
- (d) above a gas meter/**regulator** assembly within 3 ft (0.9 m) horizontally of the vertical centerline of the **regulator**;
- (e) within 6 ft (1.8 m) of any gas **service regulator vent** outlet;
- (f) less than 1 ft (30.5 cm) above grade level;
- (g) within 12 inches (30.5 cm) of a window or door, which can be opened in any building, any non-mechanical air, **supply** inlet to any **building** or the **combustion air** inlet of any other **appliance**.

Installation (Venting) continued-

- (h) underneath a verandah, porch or deck, unless:
- the verandah, porch or deck is fully open on a minimum of two sides beneath the floor, and
 - the distance between the top of the vent termination and the underside of the verandah, porch or deck is greater than 1 ft (30.5 cm).

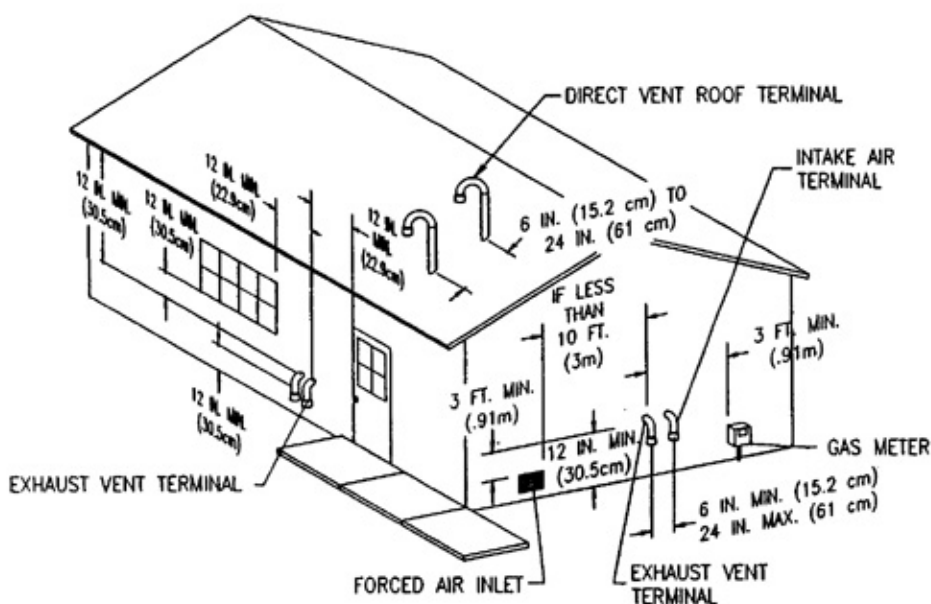

Figure 2

Horizontal And Vertical Direct Vent Lengths for 199,999 and 150,000 Btu/hr. Input Models

Reference the Venting Component Tables listed in the Installation (Direct Vent System Installation) for the maximum vent lengths using 3" (7.6 cm) diameter PVC, ABS or CPVC piping. If longer venting distances are required than shown for 3" (7.6 cm) diameter pipe, then 4" (10.2 cm) diameter pipe may be used. The distances shown in the tables are for each separate pipe (air intake and exhaust vent).

Do not exceed the maximum allowed exhaust vent or combustion air pipe distances for the number of elbows listed. Refer to the venting distances listed in tables 1-4 in this installation and operating instruction manual.

Note: The supplied exhaust vent and combustion air intake terminals may be used to vent through outside walls of any thickness as long as the maximum allowed venting distances are not exceeded.

Maximum Venting Distances (Horizontal, Vertical, or Combined for models under 200,000 Btu/hr. input ratings only)

TABLE 1 – EXHAUST VENT AND COMBUSTION AIR INTAKE PIPE LENGTHS FOR 3" (7.6 cm) PVC	
Number of 90° Elbows (Excluding vent terminals)	Maximum distance of straight pipe (excluding vent terminal) to exterior wall or roof.
1	40 ft. (12.19 m)
2	35 ft. (10.67 m)
3	30 ft. (9.14 m)
4	25 ft. (7.62 m)

TABLE 2 – EXHAUST VENT AND COMBUSTION AIR INTAKE PIPE LENGTHS FOR 4" (10.2 cm) PVC (For distances longer than 3" (7.6 cm) PVC)	
Number of 90° Elbows (Excluding vent terminals)	Maximum distance of straight pipe (excluding vent terminal) to exterior wall or roof.
1	55 ft. (16.8 m)
2	50 ft. (15.2 m)
3	45 ft. (13.7 m)
4	40 ft. (12.2 m)

Note: Each 90° elbow reduces the maximum venting distance by 5 ft. (1.52 m). Two 45° elbows are equal to one 90° elbow. Do not use 4" (10.2 cm) diameter PVC for venting distances less than 40 ft. (12.19 m) (with 1 elbow). Use 3" (7.6 cm) PVC for venting distances of 40 (12.19 m) feet or less.

The total combined distances of vertical and horizontal pipe with equivalent elbow lengths cannot exceed the maximum distance of straight pipe listed in the tables 1-4.

IMPORTANT

Do not exceed the venting distances or the number of elbows listed above. Exceeding the maximum venting distances may cause the water heater to malfunction or cause an unsafe condition.

Direct Vent System Installation (199,999 and 150,000 Btu/hr. input models)

⚠ WARNING

The direct vent system must be properly installed. Failure to properly install the direct vent system could result in property damage, personal injury or death.

Do not install any damaged direct vent system components. Contact the manufacturer of the water heater for replacement parts. Use only the vent terminals provided or factory authorized for venting this water heater.

The flow of combustion air must not be restricted. Keep the direct vent terminal openings clear of objects, shrubs, snow and debris.

⚠ WARNING

The water heater requires its own separate venting system. Do not connect the exhaust vent into an existing vent pipe or chimney.

NOTE

The exhaust vent adaptor and gasket with mounting bolts are located inside the cardboard carton with the vent terminal. The exhaust vent adaptor and gasket must be installed on the blower outlet flange before attempting to connect the 3" (7.6 cm) diameter plastic vent pipe to the water heater.

Venting continued-

This water heater is a power direct vent appliance and is designed to vent both its products of combustion and provide the combustion air supply through 3" (7.6 cm) or 4" (10.2 cm) diameter Schedule 40 PVC, ABS or CPVC pipe to the outdoors. This water heater is designed to be vented either through the wall or vertically through the roof. The blower outlet adaptor provided in the vent kit carton and combustion air inlet connection are designed to fit 3" (7.6 cm) diameter schedule 40 plastic pipe. Remove the plastic exhaust vent adaptor and gasket from the vent kit carton. Line up the gasket screw clearance holes with the vent adaptor flange and place on top of the blower outlet flange. Assemble the adaptor with the gasket to the blower outlet using the four (4) nuts, bolts, and washers provided in the kit.

If 4" (10.2 cm) diameter pipe is used, a bell reducer must be used at the blower outlet and air intake connections. Seal the joint between the PVC pipe and the blower outlet collar with silicone sealant (not supplied) (See figure 3). Table 1 lists the maximum vent lengths for this water heater using 3" (7.6 cm) PVC. If possible, locate the water heater so that the venting length and number of elbows are kept to the minimum distance necessary to reach the outside. Use the 3" (7.6 cm) vent and intake air terminals supplied with the water heater to terminate on the outside of the building. When using 4" (10.2 cm) diameter pipe, optional 4" (10.2 cm) diameter vent terminals must be used and are available from your dealer. Refer to the venting illustrations on the following pages. Make sure the exhaust vent pipe terminal rear edge is at least 6" (2.5 cm) away from the edge of the wall (see figure 4).

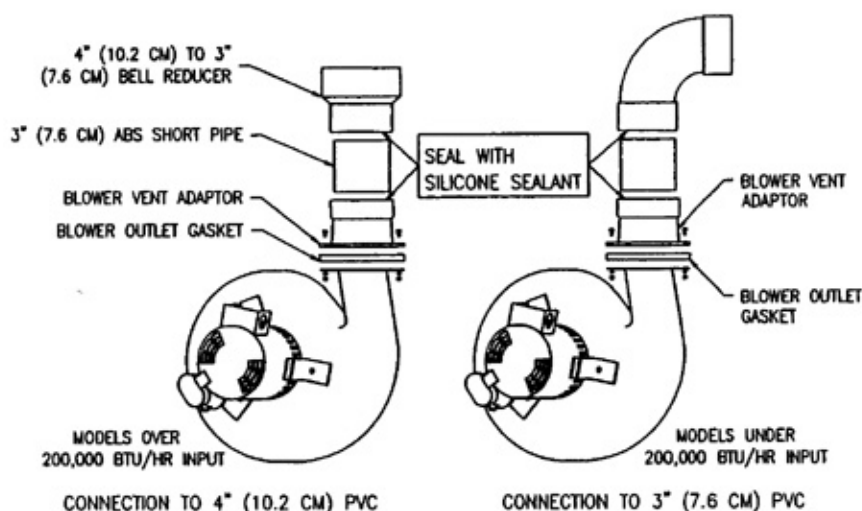

Figure 3

IMPORTANT

All of the Exhaust Venting connections must be leak checked with a soap solution upon initial start up of the water heater. Any leaks must be repaired before continuing operation of the water heater.

NOTE: ABS or CPVC pipes may be substituted for PVC pipe.

Through the Wall Venting:

Cut two 3 1/2 in. (8.9 cm) diameter holes (for 3" (7.6 cm) diameter pipe) or 4 1/2" (11.4 cm) diameter holes (for 4" (10.2 cm) diameter pipe) in the wall with the centerline hole distances at least 6" (15.2 cm) apart, but not more than 24" (61 cm) apart in the location where the exhaust vent and air intake terminals will exit the outside wall. Use the proper PVC cement to secure the 90° exhaust vent and air intake terminals provided with the water heater to the plastic pipes. The distance between the back edge of the 90° exhaust vent terminal and the exterior wall (see Figure 4) must be 5 inches (12.7 cm) more for the exhaust vent terminal than the air intake terminal. Use the proper cement and assembly procedures to secure the vent connector joints between the terminal and the blower outlet. Provide support brackets for every 3 feet (.91 m) of horizontal vent.

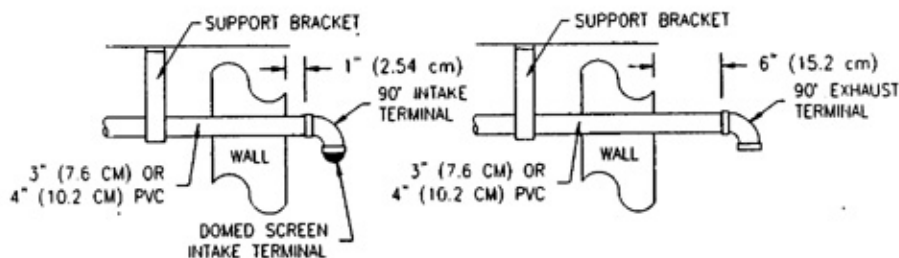

Figure 4

Through the Roof Venting: (Vertical Venting)

Cut the necessary holes through the roof and ceiling and install the exhaust vent and air intake plastic pipes as shown in Figure 5A. Make sure that the installation meets the local codes and/or The National Fuel Gas Code ANSI Z223.1 (Latest Edition) or CGA/CAN B149 Installation Code.

All vertical exhaust vent runs or horizontal runs more than 15 feet in length may accumulate condensate in the exhaust vent pipe and exhaust blower and will require the installation of a drain tee and condensate trap. A drain tee and condensate trap are available from your installer or the

Venting continued-

manufacturer of the water heater and must be installed in the horizontal exhaust vent as close as practical to the blower vent connection (See Figures 6B and 6C). When using the condensate tee, the exhaust vent piping must slope with a $\frac{1}{4}$ " (6.35 mm) per foot pitch toward the condensate tee. For short horizontal runs (less than 15 feet (4.57 m)) without the condensate tee, slope the exhaust vent piping toward the outside vent terminal so that any condensate will drain out the vent terminal (see figure 6A). Venting arrangements required for low ground clearance (figure 7) will require a condensate tee with the pipe sloped toward the tee.

Connect $\frac{3}{8}$ " (15.9 mm) plastic tubing from the barbed fitting on the condensate tee and form a loop using wire ties or tape as shown in figures 6B and 6C before running to a drain or condensate pump. The loop forms a drain trap so that flue gases do not escape into the room.

▲ CAUTION

A drain loop must be installed in the drain tubing to serve as a condensate trap to prevent flue gases from escaping into the room. Refer to figures 6B, 6C, and the instructions discussing the condensate drain tee and trap under the vertical venting section.

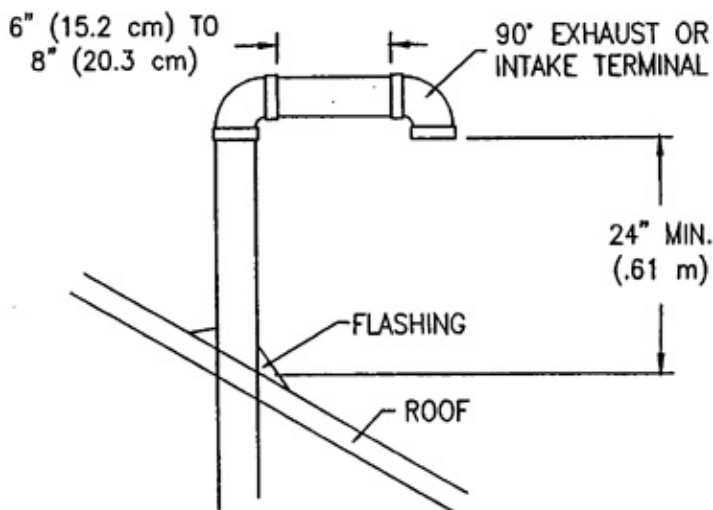

Figure 5

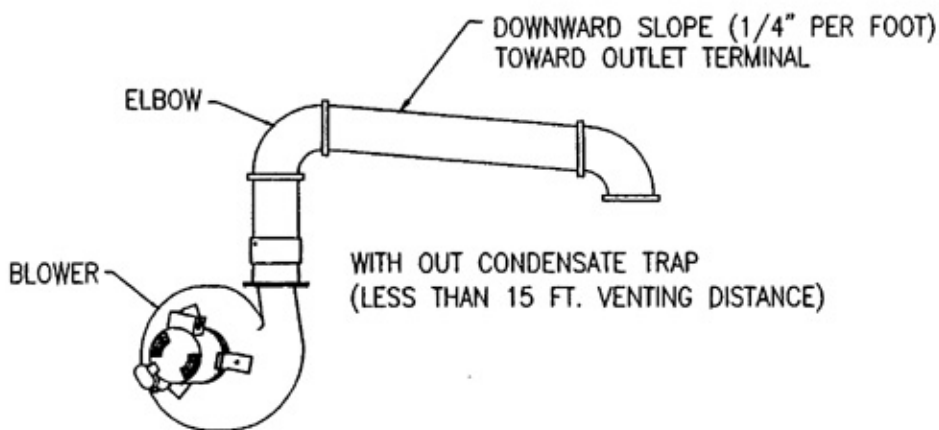

Figure 6A

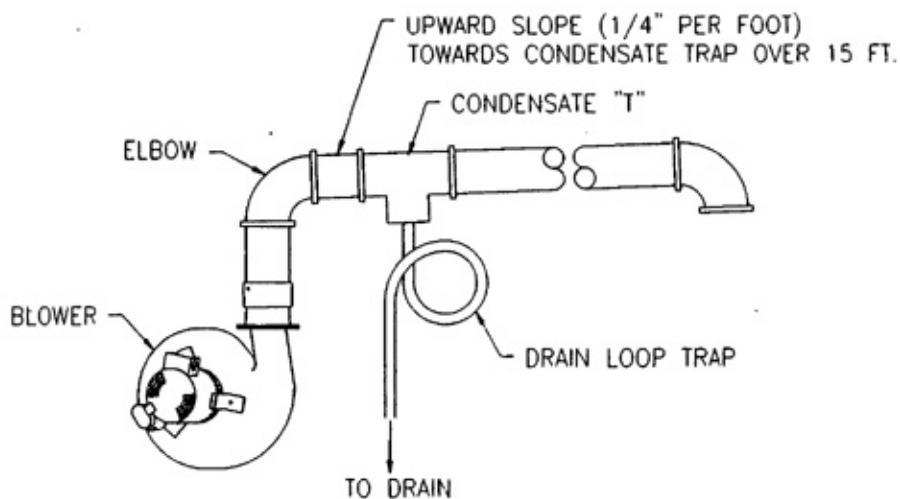

Figure 6B

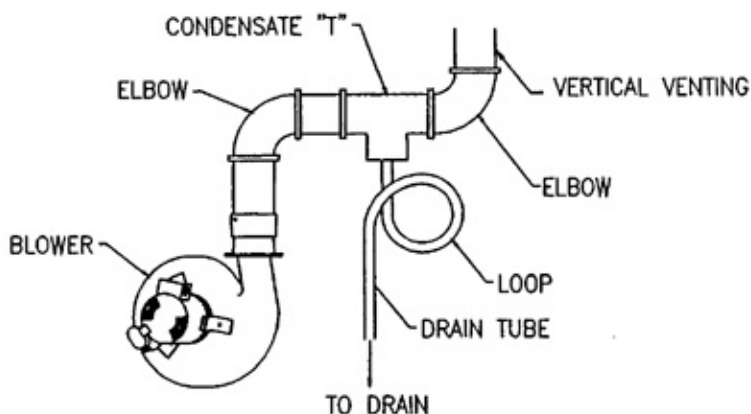

Figure 6C

Through the Wall Venting With Low Ground Clearance:

When venting cannot exit through the wall at a height greater than or equal to 12" (30.5 cm) (and above expected snow level) from the ground, then the installation must be modified as shown below (see Figure 7). Refer to Tables 3 or 4 for maximum venting lengths using 3" (7.6 cm) or 4" (10.2 cm) diameter plastic pipe.

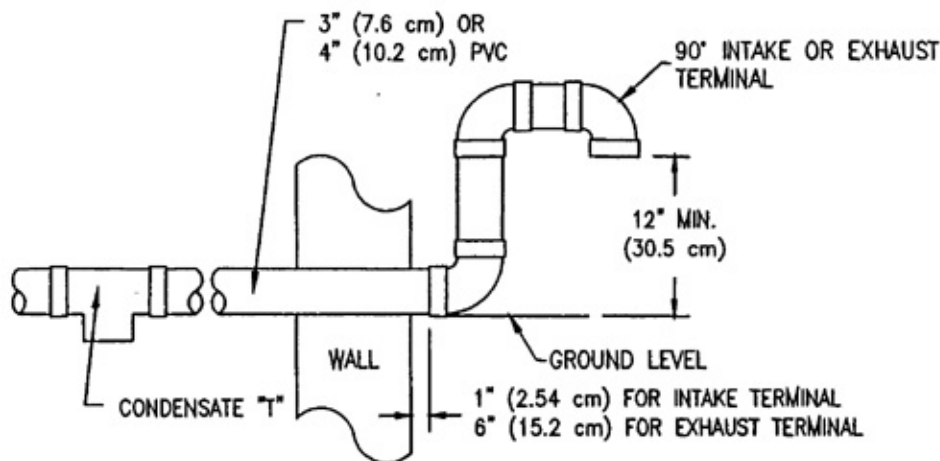

Figure 7

TABLE 3**3" (7.6 cm) PVC EXHAUST VENT OR COMBUSTION AIR INTAKE PIPE LENGTHS FROM INSIDE WALL FOR LOW GROUND CLEARANCE INSTALLATIONS**

Termination	# of Elbows	Maximum Length
(2) 90° Elbows with (1) 90° Elbow	1	30 ft (9.1 m)
(2) 90° Elbows with (1) 90° Elbow	2	25 ft (7.6 m)
(2) 90° Elbows with (1) 90° Elbow	3	20 ft (6.1 m)
(2) 90° Elbows with (1) 90° Elbow	4	15 ft (4.6 m)

TABLE 4**4" (10.2 cm) PVC EXHAUST VENT OR COMBUSTION AIR INTAKE PIPE LENGTHS FROM INSIDE WALL FOR LOW GROUND CLEARANCE INSTALLATIONS**

Termination	# of Elbows	Maximum Length
(2) 90° Elbows with (1) 90° Elbow	1	45 ft (13.7 m)
(2) 90° Elbows with (1) 90° Elbow	2	40 ft (12.2 m)
(2) 90° Elbows with (1) 90° Elbow	3	35 ft (10.7 m)
(2) 90° Elbows with (1) 90° Elbow	4	30 ft (9.1 m)

Direct Vent System Installation for Models with Input Ratings Over 200,000 Btu/Hr.

Models with input ratings over 200,000 Btu/hr. must use 4" (10.2 cm) diameter PVC, ABS, or CPVC pipe. Install the blower adaptor exhaust vent assembly and gasket supplied in the vent kit carton on the exhaust blower outlet flange as described in the previous section. Connect the 4" (10.2 cm) pipe to the 4" (10.2 cm) reducers attached to the combustion air intake pipe and blower exhaust outlet. The supplied 4" (10.2 cm) exhaust vent and combustion air intake terminals must also be used. Follow the venting system installation instructions for installing 4" (10.2 cm) diameter pipe detailed on pages 14-18 and figures 3-7 and follow the venting tables 5 and 6 for the maximum venting distances.

Maximum Venting Distances (Horizontal, Vertical, or Combined)

TABLE 5	
EXHAUST VENT OR COMBUSTION AIR INTAKE PIPE LENGTHS FOR 4" (10.2 cm) PVC	
Number of 90° Elbows (Excluding vent terminals)	Maximum distance of straight pipe (excluding vent or air intake terminal) to exterior wall or roof.
1	55 ft. (16.8 m)
2	50 ft. (15.2 m)
3	45 ft. (13.7 m)
4	40 ft. (12.2 m)

TABLE 6		
4" (10.2 cm) PVC EXHAUST VENT OR COMBUSTION AIR INTAKE PIPE LENGTHS FROM INSIDE WALL FOR LOW GROUND CLEARANCE INSTALLATIONS		
Terminating	# of Elbows	Maximum Length
(2) 90° Elbows with (1) 90° Elbow	1	45 ft (13.7 m)
(2) 90° Elbows with (1) 90° Elbow	2	40 ft (12.2 m)
(2) 90° Elbows with (1) 90° Elbow	3	35 ft (10.7 m)
(2) 90° Elbows with (1) 90° Elbow	4	30 ft (9.1 m)

Water Connections

Note: BEFORE PROCEEDING WITH THE INSTALLATION, CLOSE THE MAIN WATER SUPPLY VALVE.

After shutting off the main water supply, open a faucet to relieve the water line pressure to prevent any water from leaking out of the pipes while making the water connections to the water heater. After the pressure has been relieved, close the faucet. The COLD water inlet and HOT water outlet are identified on the top and front of the water heater. Make sure the dip tube is in place before making the cold water connection. Make the proper plumbing connections between the water heater and the plumbing system to the house. Install a shut-off valve in the cold water supply line.

▲ CAUTION

If sweat fittings are to be used, **DO NOT** apply heat to the nipples on top or side of the water heater. Sweat the tubing to the adapter before fitting the adapter to the water connections. It is imperative that heat is not applied to the nipples containing a plastic liner.

▲ WARNING

FAILURE TO INSTALL AND MAINTAIN A NEW, LISTED TEMPERATURE AND PRESSURE RELIEF VALVE WILL RELEASE THE MANUFACTURER FROM ANY CLAIM, WHICH MIGHT RESULT FROM EXCESSIVE TEMPERATURE AND PRESSURES.

If this water heater is installed in a closed water supply system, such as the one having a back-flow preventer in the cold water supply, provisions must be made to control thermal expansion. **DO NOT** operate this water heater in a closed system without provisions for controlling thermal expansion. Warranties do not cover damages from thermal expansions such as pressure bulges and/or deformities. Your water supplier or local plumbing inspector should be contacted on how to control this situation.

After installation of the water lines, open the main water supply valve and fill the water heater. While the water heater is filling, open several hot water faucets to allow air to escape from the water system. When a steady stream of water flows through the faucets, close them and check all water connections for possible leaks. **NEVER OPERATE THE WATER HEATER WITHOUT FIRST BEING CERTAIN IT IS FILLED WITH WATER.**

▲ CAUTION

Keep clear of the combination temperature and pressure relief valve discharge line outlet. The discharge may be hot enough to cause scald injury. The water is under pressure and may splash.

▲WARNING

For protection against excessive temperatures and pressure, install temperature and pressure protective equipment required by local codes, but not less than a combination temperature and pressure relief valve certified by a nationally recognized testing laboratory that maintains periodic inspection of production of listed equipment or materials as meeting the requirements of the Standard for *Relief Valves and Automatic Gas Shutoff Devices for Hot Water Supply Systems, ANS Z21.22* and the Standard *CAN1-4.4 Temperature, Pressure, Temperature and Pressure Relief Valves and Vacuum Relief Valves*. The combination temperature and pressure relief valve must be marked with a maximum set pressure not to exceed the maximum working pressure of the water heater. The combination temperature and pressure relief valve must also have an hourly rated temperature steam BTU discharge capacity not less than the hourly rating of the water heater.

Install the combination temperature and pressure relief valve into the opening provided and marked for this purpose on the water heater.

Note: Some models may already be equipped or supplied with a combination temperature and pressure relief valve. Verify that the combination temperature and pressure relief valve complies with local codes. If the combination temperature and pressure relief valve does not comply with local codes, replace it with one that does. Follow the installation instructions above on this page.

Install a discharge line so that water discharged from the combination temperature and pressure relief valve will exit within six (6) inches (15.2 cm) above, or any distance below the structural floor and cannot contact any live electrical part. The discharge line is to be installed to allow for complete drainage of both the combination temperature and pressure relief valve and the discharge line. The discharge opening must not be subjected to blockage or freezing. **DO NOT** thread, plug or cap the discharge line. It is recommended that a minimum clearance of four (4) inches (10.2 cm) be provided on the side of the water heater for servicing and maintenance of the combination temperature and pressure relief valve.

Do not place a valve between the combination temperature and pressure relief valve and the tank.

▲WARNING

Hydrogen gas can be produced in an operating water heater that has not had water drawn from the tank for a long period of time (generally two weeks or more). Hydrogen gas is extremely flammable. To prevent the possibility of injury under these conditions, we recommend the hot water faucet to be open for several minutes at the kitchen sink before you use any electrical appliance, which is connected to the hot water system. If hydrogen is present, there will be an unusual sound such as air escaping through the pipes as hot water begins to flow. Do not smoke or have open flame near the faucet at the time it is open.

This water heater can deliver scalding temperature water at any faucet in the system. Be careful whenever using hot water to avoid scalding injury. Certain appliances such as dishwashers and automatic clothes washers may require increased temperature water. By setting the thermostat on this water heater to obtain the increased temperature water required by these appliances, you may create the potential for scald injury. To protect against injury, you should install an anti-scald tempering valve in the water system. This valve will reduce point of discharge temperature by mixing cold and hot water in branch supply lines. Such valves are available from the local plumbing supplier.

Please consult with a plumbing professional. For information regarding space-heating water connections and plumbing arrangements, refer to the section, "Installation Instructions for Potable Water and Space Heating" in this Installation and Operating Instruction Manual.

	<p>Water temperatures over 125°F (52°C) can cause severe burns instantly or death from scalds. Children, disabled, and elderly are at highest risk of being scalded. See "Temperature Adjustment" section of this manual before setting thermostat at water heater. Feel water before bathing or showering. Temperature limiting valves are available, consult local plumbing supplier.</p>
--	--

Gas Connections

The gas supply lines must meet all requirements of the National Fuel Gas Code (ANSI Z223.1-Latest Edition), or in Canada CAN/CGA B149.1 Natural Gas Installation Code (Latest Edition) or CAN/CGA B149.2 Propane Installation Code (Latest Edition).

The minimum permissible gas supply pressure for the purpose of input adjustment is 1.0 inches (0.25 kPa) water column above the operating manifold pressure. See the rating plate and gas valve for the inlet and manifold pressures and gas type. The maximum permissible gas supply pressure is fourteen (14.0) inches (3.49 kPa) water column for natural gas and liquefied petroleum gases/propane gas.

1. Connect this water heater only to the type of gas (Natural or Propane gas) as shown on the rating plate. Use clean black iron pipe or equivalent material approved by local codes and ordinances. (Dirt and scale from the pipe can enter the gas valve and cause it to malfunction). The inlet gas line must have a minimum length of three (3) inches (7.62 cm) drip leg (sediment trap) installed as close to the water heater's gas valve as possible. A ground joint union must be installed in the gas supply line, as close to the water heater as possible, to permit servicing of the water heater. Compounds used on the threaded joints of the gas piping must be resistant to the action of liquefied petroleum gases/propane gas. **DO NOT** apply pipe dope to the gas valve inlet and make certain that no pipe dope has become lodged in the inlet screen of the gas valve. Extreme care must be taken to ensure no pipe dope enters the gas valve and to avoid excessive torque when tightening the gas supply line to the gas valve. Excessive torque may result in cracking of the gas valve housing. The suggested maximum torque is 31.5 ft. lbs. (4.4 kg-m). The manufacturer of this water heater will not be liable for any damage or injury caused as a result of a cracked gas inlet as a result of excessive torque.
2. This water heater and its gas connection must be leak tested before placing the water heater in operation. Check for gas leaks with a soap and water solution and a brush or a commercial leak detector fluid.
NEVER USE A MATCH OR OPEN FLAME FOR TESTING!

CAUTION

The water heater and individual shutoff valve must be disconnected from the gas supply piping system during any pressure testing of the system at test pressures in excess of 1/2 psi (3.5 kPa). The water heater must be isolated from the gas supply piping system by closing its manual shutoff valve during any pressure testing of the gas supply system at test pressures equal to or less than 1/2 psi (3.5 kPa). The supply line must be capped when not connected to the water heater.

Electrical Connections

All electrical wiring must be installed and grounded in accordance with local codes, or in the absence of local codes, the National Electrical Code, ANSI/NFPA 70 and/or the CSA C22.1 Electrical Code.

The water heater must be wired to a 115 volt, 60 Hz, AC power supply. The water heater should be wired on a separate circuit and breaker. If a flexible line cord and plug is permitted by local code, then provide a three wire grounding type receptacle within reach of the line cord provided on the control box. Do not plug the line cord into a receptacle that can have the power supply interrupted by a switch that is used to control lights or another appliance.

If wiring in conduit is required, remove the line cord and strain relief bushing in the control panel and install an electrical conduit connector. Connect the hot, neutral, and ground leads to the terminal block using quick connect terminals. Refer to the wiring diagram for the correct terminal locations for each wire lead.

CAUTION

Turn off or disconnect the electrical power supply to the water heater before servicing. Label all wires prior to disconnection when servicing controls. Wiring errors can cause improper and dangerous operation. Verify proper operation after servicing.

TYPICAL INSTALLATION

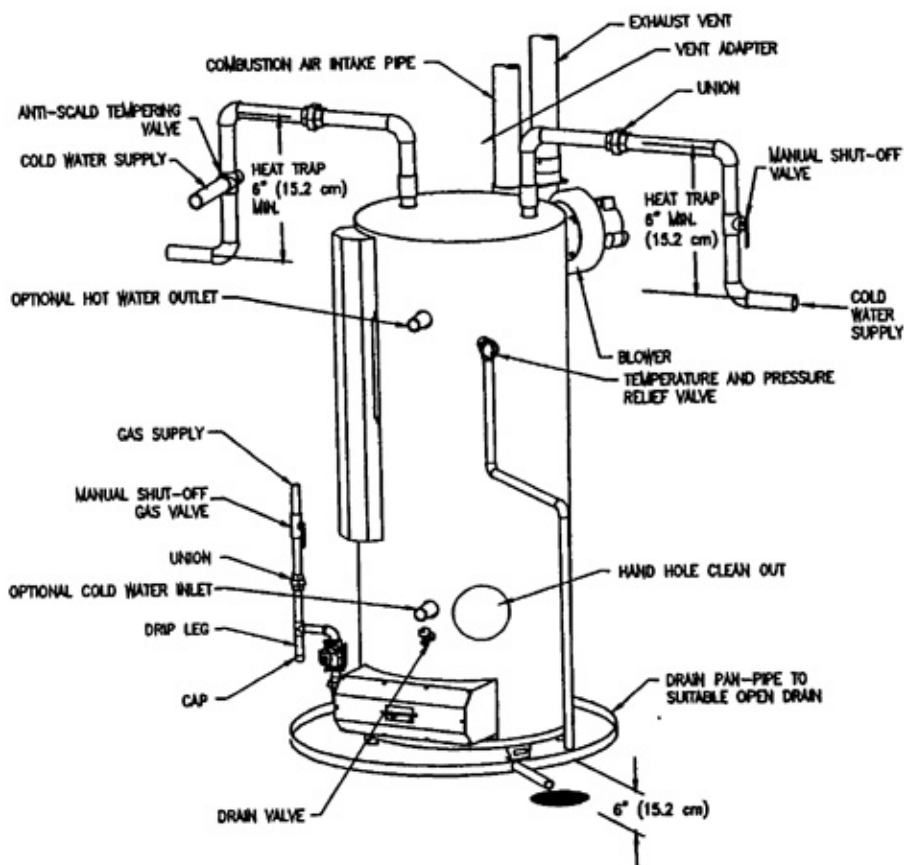

Notes: The heat trap shown above is not part of the water heater, only a piping suggestion to reduce the standby heat loss. The drain pan may be purchased from your water heater supplier.

GENERAL OPERATION

▲WARNING

Water heaters are heat-producing appliances. To avoid damage or injury there must be no materials stored against the water heater or direct vent system, and proper care must be taken to avoid unnecessary contact (especially by children) with the water heater and direct vent system.

UNDER NO CIRCUMSTANCES SHALL FLAMMABLE MATERIALS, SUCH AS GASOLINE OR PAINT THINNER BE USED OR STORED IN THE VICINITY OF THIS WATER HEATER OR IN ANY LOCATION FROM WHICH FUMES COULD REACH THE WATER HEATER.

TO FILL THE WATER HEATER

1. Close the water heater drain valve by turning the knob or valve stem clockwise. If alternative water connections are provided but not used, make certain they are plugged (i.e. rear connections).
2. Open the cold water supply shut-off valve.
3. Open several hot water faucets to allow air to escape from the system.
4. When a steady stream of water flows from the faucets, the water heater is filled. Close the faucets and check for water leaks at the water heater drain valve, combination temperature and pressure relief valve and the hot and cold water connections.

TO DRAIN THE WATER HEATER

Should it become necessary to completely drain the water heater, make sure you follow the steps below:

1. Depress the control panel rocker switch on the side of the control box to the "OFF" position. Refer to the operating instructions.
2. Rotate and partially depress gas control knob clockwise to the "OFF" position.
3. Shut off the gas supply to the water heater.
4. Close the cold water supply shut-off valve.
5. Open the drain valve or valve stem on the water heater by turning the knob counter-clockwise. The drain valve has threads on the end that will allow the connection of a standard hose coupling.
6. Open a hot water faucet to allow air to enter the system.

To refill the water heater, refer to "To Fill the Water Heater."

Lighting And Shutdown Instructions

FOR YOUR SAFETY READ BEFORE LIGHTING

WARNING: If you do not follow these instructions exactly, a fire or explosion may result causing property damage, personal injury or loss of life.

- A. This appliance is equipped with an ignition device which automatically lights the pilot. Do not try to light the pilot by hand.
- B. **BEFORE OPERATING** smell all around the appliance area for gas. Be sure to smell next to the floor because some gas is heavier than air and will settle on the floor.
- WHAT TO DO IF YOU SMELL GAS**
- Do not try to light any appliance.
 - Do not touch any electric switch; do not use any phone in your building.
 - Immediately call your gas supplier from a neighbor's phone. Follow the gas supplier's instructions.
 - If you cannot reach your gas supplier, call the fire department.
- C. Use only your hand to push in or turn the gas control knob. Never use tools. If the knob will not push in or turn by hand, don't try to repair it, call a qualified service technician. Force or attempted repair may result in a fire or explosion.
- D. Do not use this appliance if any part has been under water. Immediately call a qualified service technician to inspect the appliance and to replace any part of the control system and any gas control which has been under water.

OPERATING INSTRUCTIONS

1. **STOPI** read the safety information above on this label.
2. Set the thermostat to lowest setting.
3. Turn off all electric power to the appliance.
4. This appliance is equipped with an ignition device which automatically lights the pilot. Do not try to light the pilot by hand.
5. Turn gas control knob clockwise ↷ to "off".
6. Wait five (5) minutes to clear out any gas. If you then smell gas, **STOPI** Follow "B" in the safety information above on this label. If you don't smell gas, go to next step.
7. Turn gas control knob counterclockwise ↶ to "ON".
8. Turn on all electric power to the appliance.
9. Set thermostat to desired setting.
10. If the appliance will not operate, follow the instructions "To Turn Off Gas To Appliance" and call your service technician or gas supplier.



GAS CONTROL KNOB SHOWN IN "OFF" POSITION

TO TURN OFF GAS TO APPLIANCE

1. Set the thermostat to lowest setting.
2. Turn off all electric power to the appliance if service is to be performed.
3. Turn gas control knob clockwise ↷ to "OFF".

▲ CAUTION

Do not use this appliance if any part has been under water. Immediately call a qualified service technician to inspect the appliance and to replace any part of the control system including gas controls, which has been under water.

Temperature Adjustment

The temperature selector knob of the thermostat has been adjusted to its lowest setting when shipped from the factory.

The detent on the thermostat temperature scale (see figure 8) is the preferred starting point for setting the temperature control. For energy-efficient operation of your water heater, the suggested initial temperature setting is approximately 130°F (55° C). Households with small children or invalids may require a 120°F (49° C) or lower temperature setting to reduce the risk of scald injury. Some states require a lower temperature setting. NOTE: The lower the temperature setting, the greater the energy efficiency, both to heat the water and to maintain the storage temperature during standby periods. Lower water temperatures also extend tank life. Remember, no water heating system will provide exact temperatures at all times. Allow a few days of operation at this setting to determine the correct temperature setting consistent with the requirements for the installation. NOTE: This water heater, when set at a lower temperature setting, is not capable of producing hot water of sufficient temperature for sanitizing purposes.

During the winter season or any cold period, you may desire a higher temperature setting to adjust for the colder incoming water. This adjustment, however, may cause additional condensation to form on the cooler tank surface. This does not mean the tank is leaking. During summer months, the warmer incoming water temperatures will benefit the performance of your water heater and reduce the amount of condensation developed.

Condensation does not mean your tank is leaking. Over 40% of reported tank leaks on installation are proven to be condensation. To avoid unnecessary inconvenience and expense, make sure the tank is leaking before calling a service person.

General Operation (Temperature Adjustment) continued-

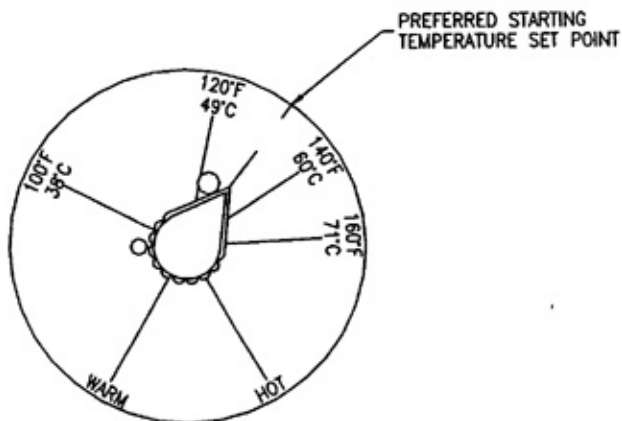

Figure 8

▲ DANGER

Hotter water increases the risk of scald injury. Scalding may occur within five (5) seconds at a temperature setting of 135°F (57°C). To protect against hot water injury, install an anti-scald tempering valve in the water system. This valve will reduce point of discharge temperature by mixing cold and hot water in branch water lines. A licensed plumbing professional or local plumbing authority should be consulted.

Note: This water heater is equipped with an energy cut out device to prevent overheating. Should overheating occur or the gas supply fail to shut off, turn off the manual gas control valve to the appliance and call a qualified service technician.

Note: Whenever the water heater is filled with cold water, condensate will form on the cool tank surface and drops of water will fall on the hot burner and combustion chamber surfaces producing a "sizzling" noise. Condensation is normal and does not indicate a leak. It will disappear when the tank becomes heated.

An automatic gas shut-off device (ECO) is incorporated in the thermostat circuit, which will shut off all gas supply to the burner and pilot if the water heater temperature exceeds 200°F (93°C). Should the ECO function (open), the water temperature should be reduced to approximately 120°F (49°C) and the Lighting Instructions followed to place the water heater in operation. Refer

to the "Lighting and Shutdown Instructions" section of this Installation and Operating Instructions Manual. If a problem exists, contact your dealer for service. It is recommended that all service work be performed by a qualified service agency.

If the water heater is to remain idle for 30 days or more or is subjected to freezing temperatures while shut off, the water heater and piping should be fully drained and the drain valve should be left fully open. Refer to the "General Operation" section of this Installation and Operating Instructions Manual for the procedure on draining the water heater.

Burner Flame Check

At the time of installation and at periodic intervals (at least once a year), a visual check of the pilot and burner flames should be made to determine if they are burning properly. The main burner and pilot flame may be viewed through the viewing window on the front of the combustion air box. An adjustment to the air shutter setting is not normally required for this heater. Some Liquefied Petroleum / Propane gas (LP) models may be pre-adjusted at the factory with the burner air shutters closed most of the way. The burner flames should be blue with yellow tips. A blue-orange flame is characteristic of operation on LP gas. The burner tube flames should light smoothly from the pilot.

If the burners resonate during warm-up (produce a harmonic noise and vibration, usually when operating with LP gas), close down the burner air shutters until the resonance stops. The resonance during burner operation should only be checked with the front panel held in place, since resonance may be more pronounced with the front panel off. Check to make sure the burner flame appearance is satisfactory after adjusting the burner air shutters (see above).

IMPORTANT

In the event of an emergency, turn off the gas and electric (if applicable) to the appliance.

General Operation (Burner Flame Check) continued-

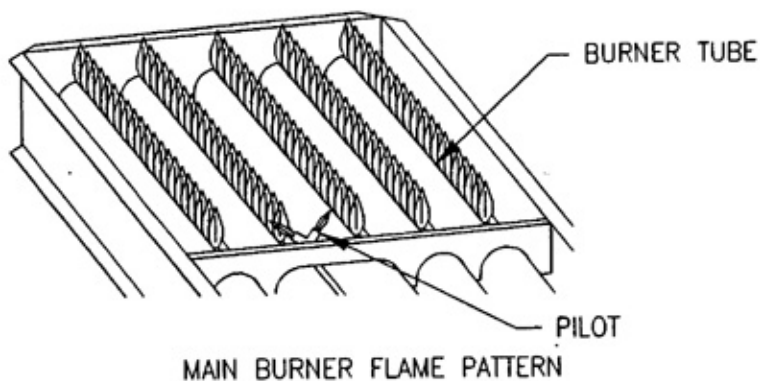
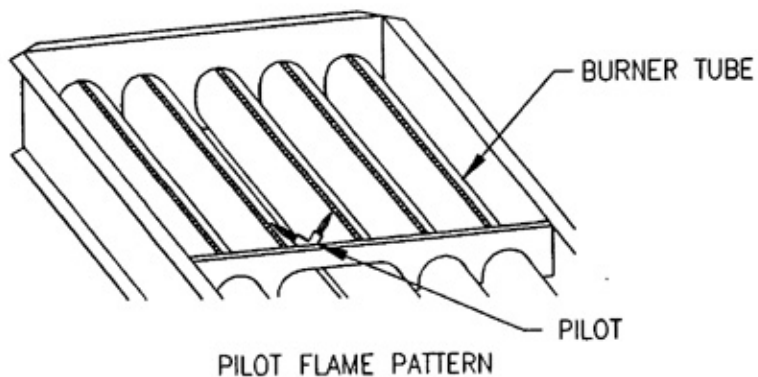

Figure 9

Note: Actual burner may not appear as shown in Figure 9.

MAINTENANCE

▲WARNING

Water heaters are heat-producing appliances. To avoid damage or injury there must be no materials stored against the water heater or vent system, and proper care must be taken to avoid unnecessary contact (especially by children) with the water heater and vent system. **UNDER NO CIRCUMSTANCES SHALL FLAMMABLE MATERIALS, SUCH AS GASOLINE OR PAINT THINNER BE USED OR STORED IN THE VICINITY OF THIS WATER HEATER, VENT SYSTEM OR IN ANY LOCATION FROM WHICH FUMES COULD REACH THE WATER HEATER OR VENT SYSTEM.**

IMPORTANT

The water heater should be inspected at a minimum annually by a qualified service technician for damaged venting system components and/or vent and combustion air supply joints not sealed. DO NOT operate this water heater if any part is found damaged or if any joint is found not sealed.

A qualified service technician should perform the following maintenance at the minimum periodic intervals suggested below. In some installations, the maintenance interval may be more frequent depending on the amount of use and the operating conditions of the water heater. Regular inspection and maintenance of the water heater will help to insure safe and reliable operation.

1. Annual checks of the ignition systems, temperature controls and any other water heater controls are necessary to ensure proper operation. Also, all safety shut-off valves must be checked to verify proper operation and tightness.
2. The entire combustion system must be sealed for this water heater to function properly. Make sure the burner access panel is kept tightly sealed. The combustion air supply pipe at the rear of the water heater must be tightly sealed to the dilution air tee and combustion air boot. Replace any damaged parts. The entire venting system and combustion air supply parts must be inspected at least annually for integrity of all joints.
3. The flow of combustion and ventilation air **MUST NOT** be restricted. Keep the direct vent terminal openings clear of objects, shrubs, snow, and debris. Check to make sure the vent terminal is not damaged.

Maintenance continued-

4. At all times keep the water heater area clear and free from combustible materials, gasoline and other flammable vapors and liquids.
5. Annually conduct a visual check of the pilot and burner flames to determine that they are burning properly. See "Burner Flame Check" section for an illustration of the proper burner flame pattern.
6. At annual intervals check the flue baffles for deterioration and scale or carbon deposits. Clean if necessary and brush the flue tubes if excessive scale or deposits are found on the baffles. Replace any baffles that have become excessively warped or deteriorated. Check the flue collector gasket for integrity and replace if necessary. Cleaning of the flue baffles and flue tubes should be done prior to cleaning the burners, since deposits may fall on the burners during cleaning or checking the baffles.
7. Annually remove the main burner rack assembly to clean orifices and related parts of any dirt or other foreign material. Inspect the burner ports for obstructions or debris and clean with a wire brush, vacuum, or use a mild detergent solution to clean as needed. Inspect the pilot. Carefully clean the electrode and flame sense rod with emery cloth. The spark electrode (rod closest to the pilot hood) gap should be 1/8" (3.2 mm).
NOTE: It is imperative for proper operation of the water heater that the main burner rack be replaced in the original location.

To remove the burner rack assembly, follow the procedure outlined below:

- a) Shut off the gas and electrical supply to the water heater.
- b) Remove the pilot tube fittings at the gas valve and combustion box.
- c) Disconnect wires to gas valve. Open control box and disconnect pilot spark and flame sense wires. Remove the wire raceway cover below the control box.
- d) Disconnect the gas pipe union below the gas valve.
- e) Remove the three screws securing the gasketed manifold pipe flange on the left side of the combustion box.
- f) Remove the burner access panel screws and lower the hinged panel.
- g) Carefully remove and push the pilot wire grommet into the combustion box with the pilot wires.
- h) Disconnect the pilot tube fitting on the inside bulkhead fitting of the combustion box.
- i) Unthread the gas pipe assembly from the manifold inside the combustion box.
- j) Remove the screw securing the curved burner shroud on the top center securing the burner assembly to the tank skirt.
- k) Slide out the burner rack assembly.

Maintenance continued-

- l) To remove the individual burners from the rack, the burner assembly shroud assembly must be removed from the burner rack by removing the four (4) screws securing the shroud to the rack. **The shroud must be reattached to the burner rack after reinstalling the burners back in the rack.**

To reinstall the burner rack, reverse the above procedure.

Alternate method for removing the burner rack, when there is at least 20" (50.8 cm) clearance on the left front side:

- a) Shut off the gas and electrical supply to the water heater.
- b) Disconnect both pilot tube fittings at the combustion box bulkhead fitting.
- c) Disconnect wires to gas valve. Open control box and disconnect pilot spark and flame sense wires. Remove the wire raceway cover below the control box.
- d) Disconnect the gas pipe union either above or below the gas valve.
- e) Remove the three screws securing the gasketed manifold flange on the left side of the combustion box.
- f) Remove the burner access panel from the front of the combustion box.
- g) Carefully remove and push the pilot wire grommet into the combustion box with the pilot wires.
- h) Remove the four screws securing the manifold to the burner rack.
- i) Carefully remove the manifold through the left side opening in the combustion box.
- j) Remove the screw securing the curved burner shroud on the top center securing the burner assembly to the tank skirt.
- k) Slide out the burner rack assembly.
- l) To remove the individual burners from the rack, the burner assembly shroud assembly must be removed from the burner rack by removing the four (4) screws securing the shroud to the rack. **The shroud must be reattached to the burner rack after reinstalling the burners back in the rack.**

To reinstall the burner rack, reverse the above procedure.

▲WARNING

When lifting lever of the combination temperature and pressure relief valve, hot water will be released under pressure. Be careful that any released water does not result in bodily injury or property damage.

- At least once a year, check the combination temperature and pressure relief valve to insure that the valve has not become encrusted with lime. Lift the lever at the top of the valve several times until the valve seats properly without leaking and operates freely.

▲ CAUTION

Keep clear of the combination temperature and pressure relief valve discharge line outlet. The discharge may be hot enough to cause scald injury. The water is under pressure and may splash.

- Monthly drain off a gallon of water to remove silt and sediment.

▲ WARNING! THIS WATER MAY BE HOT.

- If the combination temperature and pressure relief valve on the appliance discharges periodically, this may be due to thermal expansion in a closed water supply system. Contact the water supplier or local plumbing inspector on how to correct this situation. Do not plug the combination temperature and pressure relief valve outlet.
- All models are equipped with a cleanout opening to aid in removal of hard water deposits from the tank bottom. If this water heater operates under hard water conditions, the following should be performed at least every 3 months: Drain the water heater. Remove the cleanout jacket cover and tank cover. When cleaning the tank, care must be taken to avoid trying to break deposits loose as this could damage the glass lining and shorten the life of the water heater. After cleaning, replace the cleanout tank cover and jacket cover, and refill with water. Refer to the section, "General Operation" in this Installation and Operating Instruction manual for the procedures for filling and draining the water heater.
- Four sacrificial anode rods have been installed in the tank head to extend tank life. The anode rods should be inspected periodically for corrosion and replaced when necessary to prolong tank life. Water conditions in your area will influence the time interval for inspection and replacement of the anode rod. The use of a water softener may increase the speed of anode consumption. More frequent inspection of the anode is needed when using softened (or phosphate treated) water. Contact the plumbing professional who installed the water heater or the manufacturer listed on the rating plate for anode replacement information.
- The induced draft blower motor used in this model series has sealed bearings and does not have provisions for oiling the bearings.

▲CAUTION

FOR YOUR SAFETY, DO NOT ATTEMPT REPAIR OF COMBINATION GAS CONTROL, BURNERS OR GAS PIPING. REFER REPAIRS TO A QUALIFIED SERVICE TECHNICIAN.

Contact your supplier, plumbing professional or contact the company at the address given on the rating plate of the water heater for replacement parts.

Provide the part name as well as the model and serial number(s) of the water heater(s) when ordering parts.

READ THE WARRANTY FOR A FULL EXPLANATION OF THE LENGTH OF TIME THAT PARTS AND THE WATER HEATER ARE WARRANTED.

Manufactured under one or more of the following U.S. Patents:

4,416,222; 4,628,184; 4,669,448; 4,672,919; 4,808,356; 4,829,983;
4,861,968; 4,867,106; 4,904,428; 5,000,893; 5,023,031; 5,052,346;
5,081,696; 5,092,519; 5,115,767; 5,199,385; 5,277,171; 5,341,770;
5,372,185; 5,485,879; 5,574,822; 5,761,379; 5,596,952; 5,660,165;
5,682,666; 5,943,984; 5,954,492; 5,988,117; 6,142,216. Other U.S. and
Foreign patent applications pending. Current Canadian Patents:
1,272,914; 1,280,043; 1,289,832; 2,045,862, 2,112,515.

Complete the following information and retain for future reference:

Model No: _____

Serial No: _____

Service Phone

Days: _____ Nights: _____

Address: _____

Supplier: _____

Supplier Phone No: _____

OPERATING AND TROUBLESHOOTING GUIDE

Sequence of Normal Operation (Electronic Thermostat with Intermittent Pilot Ignition)

1. The electronic thermostat controls the 24-volt circuit to the ignition control. When the thermostat contacts close, a 24-volt circuit is completed from the transformer through the thermostat relay to the blower relay to start the induced draft blower.
2. When the blower reaches operating speed, the air pressure switch contacts close. Low voltage goes through the normally closed vent safety switch contacts completing the 24 volt circuit to the ignition control module to start the ignition sequence.
3. After the 15 second pre-purge period, the ignition control sends 24-volt power through the normally closed high limit (ECO) contacts to the pilot valve "PV" terminals on the gas valve allowing pilot gas to flow to the pilot. The ignition control also simultaneously sends high-voltage/ low-current electricity through the electrode wire to the pilot electrode causing sparks at the pilot electrode to ignite the pilot gas. If the pilot fails to ignite within 90 seconds, the ignition control stops the pilot gas and sparking for 15 seconds to allow gas to dissipate. The ignition control will then attempt 2 (two) more ignition trials as stated above. If the pilot does not ignite after 3 trials, the ignition control will then go into a "lockout mode", and the ignition system will remain shut down until the control is **reset** by interrupting power to the ignition module. The induced draft blower continues to run during this period.
4. When the pilot gas ignites, the flame is sensed by the electrode or a flame-sensing rod. The flame-sensing signal received by the ignition control causes the sparking to stop and the main gas valve to open. The main burners ignite from the pilot flame. The flame sensing circuit continually monitors the pilot flame. If for any reason, the electrode or flame-sensing rod does not sense the pilot flame, the main gas valve closes, the spark electrode is re-energized, and the ignition trial period is reestablished. The same sequence occurs during a power or gas supply interruption.
5. The main burners continue to operate until the water temperature in the tank increases enough to cause the thermostat contacts to open (satisfied). When the thermostat contacts open the 24-volt power is interrupted to the ignition control module and the gas valve closes. The induced draft blower simultaneously stops.
7. If for some reason thermostat contacts fail to open, then the high temperature limit (ECO) contacts in the thermostat sensor open and interrupts power to the pilot valve causing the pilot to extinguish. The

ignition module senses the pilot outage and attempts to re-light the pilot by re-establishing the sparking at the electrode as stated in paragraph 3 above. Since the pilot valve circuit is open, the pilot will not ignite and the system will go into "lockout mode" after 3 ignition trials. In the "lockout mode", the ignition system will remain shutdown until the control is reset by interrupting power to the ignition module. The ECO will not reset to close the contacts until the tank water temperature drops to between 100°F (38°C) and 160°F (71°C). If the ECO contacts open, the cause for the high water temperature should be determined before resetting the ignition system.

8. If the venting system (either intake or exhaust) becomes blocked, the air pressure switch will open the contacts and stop power to the ignition control and cause the gas valve to open. If the vent temperatures become excessively high (over 200°F), the vent safety switch contacts on the outlet of the blower housing will open and interrupt power to the ignition control. This switch must be manually reset by pressing the red button on the control. The cause of the excessive temperatures must be determined before resuming normal operation.

Electrical Troubleshooting Procedure

Before proceeding with the following section, please carefully review the previous sequence of operation to have a clear understanding of the proper operation of the water heater.

If water temperature is **too hot**, proceed as follows: First verify that the hot water discharged from a nearby faucet is well above the setpoint temperature.

Test Condition:

Test Procedure:

Corrective Action:

<p>Start - Disconnect sensor leads from electronic thermostat board and measure resistance of sensor(s) with ohmmeter. Sensor wires are gray for upper sensor, blue for lower sensor. See figures 10 and 12 for these components and terminal locations.</p>	<p>Disconnect sensor leads from electronic thermostat board and measure resistance of sensor(s) with ohmmeter. Is resistance between 700 and 30K ohms (see "temperature control servicing procedure table" in this instruction manual)? Measure water temperature from the tank for an approximate correlation with the table.</p> <p>YES↓ NO→</p>	<p>Sensor(s) may be defective. Replace sensing bulb(s) if necessary.</p>
--	---	--

Troubleshooting Procedure continued-

Test Condition:	Test Procedure:	Corrective Action:
Test Potentiometer (Temperature Control Adjustment – Attached to Control Panel Cover)	Disconnect potentiometer leads from electronic thermostat board. Measure resistance of potentiometer with an ohmmeter. Is resistance greater than 4800 ohms at minimum temperature setting (checks for short)? YES↓ NO→	Replace potentiometer. Reconnect all leads and check out system.
Potentiometer O.K.	All above checks have been made, but outlet temperature is still well above setpoint.	Replace electronic thermostat board. Reconnect all leads and check out system

If water temperature is too cold or the water heater does not come on, proceed as follows: Water temperature at a nearby faucet is either cold or well below the temperature setpoint.

Test Condition:	Test Procedure:	Corrective Action:
Start: Check line voltage and "24V" and "HOT ONLY" terminals of thermostat board. See figure 10 for illustration of thermostat board and the wire terminals.	First check line voltage power supply and transformer output before checking voltage at the thermostat board to assure there is power to the water heater and thermostat board. Is voltage between "24V" and "HOT ONLY" terminals of the thermostat board between 21.5 and 28.5 VAC? YES↓ NO→	Correct condition or replace components.
Are the main burners operating or is the pilot trying to light (sparking)? YES↓ NO→	Check for voltage between the COM thermostat terminal and ground. Is the voltage between 21.5 and 28.5 VAC? YES↓ NO→	Thermostat relay is not closing. Check thermostat setting. Refer to thermostat troubleshooting toward the end of the troubleshooting section.
Are the main burners operating? Check the Induced draft blower operation. If the pilot does not light and the pilot is not sparking, check to make sure the induced draft blower is operating. Is the blower operating? YES↓ NO→	1. Check blower circuit wiring. With a voltmeter probe terminal 3 on the relay to ground. The meter should read 24 volts. 2. Next, probe terminal 4 of the relay (wire going from relay to blower) to ground. The meter should read around 115 volts. If not, check terminal 2 of the relay.	If 115 volts is present at terminal #2 of the relay, and the thermostat is supplying 24 volts to the relay coil, replace the relay.
Burners and blower not operating – continued. Relay closes, but blower does not operate. Electrically test for defective blower motor.	3. Open blower junction box cover, turn off power and disconnect leads. Turn power back on and measure voltage between the black and white wires.	If 115 volts is present, replace blower. If no voltage, check wire terminals, wires, or relay.

Test Condition:

Blower operates, but burners remain off. Pilot does not spark during ignition trial period (allow 15 seconds after blower starts). Verify by opening the hinged burner access cover.

Test pressure switch, check venting system.

Note: The pressure switch is located under a cover on the top left rear of the jacket between the control panel and blower.

The vent safety switch is located near the discharge of the blower. Follow the wire harness from the pressure switch to the vent safety switch on the blower.

Test Procedure:

1. Check for 24 volts between #2 (THS) terminal of the ignition control module and ground.
2. If 24 volts is not present at THS terminal on the ignition control and 24 volts is present at the relay terminal (COM) of the thermostat (to relay and pressure switch), check to see if pressure switch is closed. Pull terminals off part way and probe each switch terminal to ground. If 24 volts is not present at both terminals, switch is not closing.
3. If pressure switch is closed, but voltage is not present at THS terminal, check the vent safety switch near the outlet of the blower housing. The contacts are normally closed. If the contacts are open, the switch must be manually reset by depressing the red button.

Corrective Action:

1. Make sure vacuum tubing is securely connected to switch body; tubing is not kinked or has a pinhole leak. Check for plugged vent terminal. Is the venting distance to proper specifications (see previous venting installation section)? If everything checks out and switch will not close, replace pressure switch and recheck.
2. Check for any conditions that may cause the vent temperatures to be excessively high, such as the burner access cover loose, missing screws, broken viewing window, or defective or missing gaskets. This cover must be kept tightly sealed for proper operation.

Test Condition:	Test Procedure:	Corrective Action:
<p>Burners not operating. (continued)</p> <p>Does pilot spark without lighting pilot?</p> <p>Check inlet gas pressures, pilot, and test gas valve.</p> <p>Refer to figure 12 for view of the gas valve, pressure taps, and wire terminal connections.</p>	<ol style="list-style-type: none"> 1. Make sure there is sufficient gas pressure at the gas valve inlet. 2. Check the nameplate for minimum gas supply pressures for the type of gas used. 3. Check for plugged pilot orifice. 4. Check for improper pilot electrode gap or broken wire or loose connection. 5. Check for pinched pilot tubing and/or loose compression fittings. 6. Electrically test the gas valve by measuring the voltage between "PV" and "PV/MV" on the gas valve terminals. 7. Electrically test the ignition control by measuring the voltage between "PV" and "GROUND" on the ignition control module. 	<ol style="list-style-type: none"> 1. If the pilot valve will not open when 24 volts is present between the PV terminal and the common terminal ("PV/MV") on the gas valve, the gas valve may be defective. Replace gas valve. 2. If 24 volts is not present when testing between the "PV" and GROUND terminals on the ignition control and the ECO is closed, the ignition control may be defective. Replace and recheck system. 3. Pilot electrode gap should measure about 3/32". Regap and clean electrode and sensor rod if necessary. Replace pilot if wires are worn or orifice is plugged. 4. Correct any problems with the pilot tubing or fittings.

Test Condition:	Test Procedure:	Corrective Action:
<p>Burners not operating. (continued).</p> <p>Test high limit control.</p> <p>Refer to figure 11 for illustration of lower sensor.</p>	<ol style="list-style-type: none"> 1. Check gas valve for 24 volts by measuring voltage between "PV" terminal on gas valve and ground. If no voltage, check continuity across ECO circuit of lower thermostat sensor (red wires). 2. If ECO is open, it should reset after tank cools below 160° F (71° C). If it does not reset, replace the lower sensing bulb with the ECO. If ECO has opened, there may be a problem with the thermostat. 	<p>Replace lower thermostat sensor with ECO, if defective. Make sure wire harness is not defective before replacing ECO. (Check for continuity at the sensor ECO pin terminals. If there is continuity, check for continuity through the wire harness terminals).</p>
<p>Pilot lights, but main burners do not come on.</p> <ol style="list-style-type: none"> 1. Pilot flame appearance. 2. Pilot flame sense wire continuity. 3. Check pilot flame sense rod. 4. Check gas inlet pressures. 	<ol style="list-style-type: none"> 1. Check pilot flame appearance. Make sure pilot flame is steady and envelops the flame sensor rod. 2. Check pilot flame sense rod and wire. Look for any traces of carbon or corrosion on the rod. The wire insulation must not be frayed or broken. Check continuity from the flame sense rod to the end of the flame sense wire terminal. 3. Check inlet pressure at the gas valve inlet pressure tap and the manifold pressure at the gas valve outlet tap using a manometer. 	<ol style="list-style-type: none"> 1. Turn pilot adjustment screw counter-clockwise to increase size of pilot flame, clockwise to reduce flame size. 2. Make sure pilot shield is in place. 3. Make sure the inlet pressure is between the minimum and maximum values listed on the nameplate labels on the water heater. Adjust the manifold pressure to the value listed on the nameplate. 4. Clean pilot flame sense rod with emery cloth. Check condition of pilot flame sense wire. Replace pilot if necessary.
<p>Pilot lights, but main gas does not come on.</p> <p>Test ignition control module and gas valve.</p> <p>Refer to figures 10 and 12 for view of components and terminals.</p>	<ol style="list-style-type: none"> 1. If pilot flame is stable, check for 24 volts between the "MV" and "PVMV" terminals on the gas valve. 2. If voltage is not present at the gas valve, check for 24 volts between MV and GROUND on the ignition control module. 	<ol style="list-style-type: none"> 1. If voltage is present at the gas valve, replace the valve. 2. If no voltage is present is present between MV and GROUND on the ignition control module, replace the control.

If the water temperature is too cold or the water heater does not come on, proceed as follows (continued from table above – **thermostat diagnosis**):

Test Condition:	Test Procedure:	Corrective Action:
<p>1. Water heater will not operate due to faulty thermostat (no power at thermostat board "COM" terminal).</p> <p>2. Water heater short cycles.</p> <p>This section is for troubleshooting the thermostat circuit for cold or insufficient hot water. If insufficient hot water, also check the usage requirements for the installation and the capacity of the water heater.</p>	<p>Disconnect sensor leads (gray wires to upper sensor, blue wires to lower sensor) from electronic thermostat board and measure resistance of sensor(s) with ohmmeter. Is resistance between 700 and 30K ohms (see "temperature control servicing procedure table" in this instruction manual)? Refer to figure 10 for terminal and component locations in the control box. Measure water temperature from T&P valve for upper sensor, drain valve for lower sensor for an approximate correlation with the table.</p> <p>YES↓ NO→</p>	<p>Sensor(s) may be shorted or open. Check continuity of wires for loose, broken, or shorted wires. Replace sensing bulb or wire harness, if necessary.</p>
<p>Sensors O.K. Check remote potentiometer.</p>	<p>Disconnect potentiometer leads from electronic thermostat. Measure resistance of potentiometer with an ohmmeter. Is resistance greater than 4800 ohms at the minimum temperature setting and less than 50 ohms at the maximum temperature setting?</p> <p>YES↓ NO→</p>	<p>Replace potentiometer. Reconnect all leads and check out system.</p>
<p>Potentiometer O.K. Check thermostat board.</p>	<p>Thermostat relay still does not close and potentiometer, sensors, and wires check out O.K.</p> <p>1. Check with a voltmeter the voltage between "24V and 24 HOT ONLY" on the thermostat board. There should be 24 volts between these two terminals.</p> <p>2. If no voltage, check the wires or transformer. If 24 volts is present between these two terminals on the thermostat board, replace the board.</p>	<p>Replace electronic thermostat board. Reconnect all leads and check out system.</p>

Lower Sensor & ECO

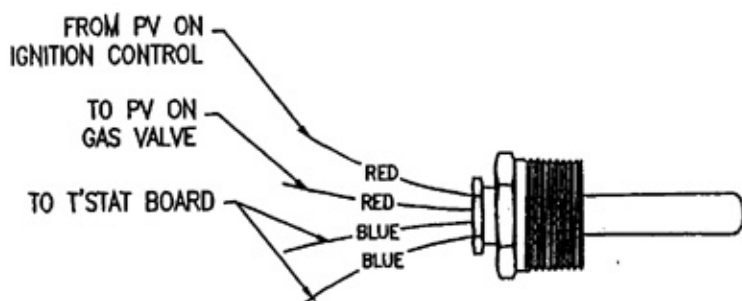

Figure 11

Gas Valve

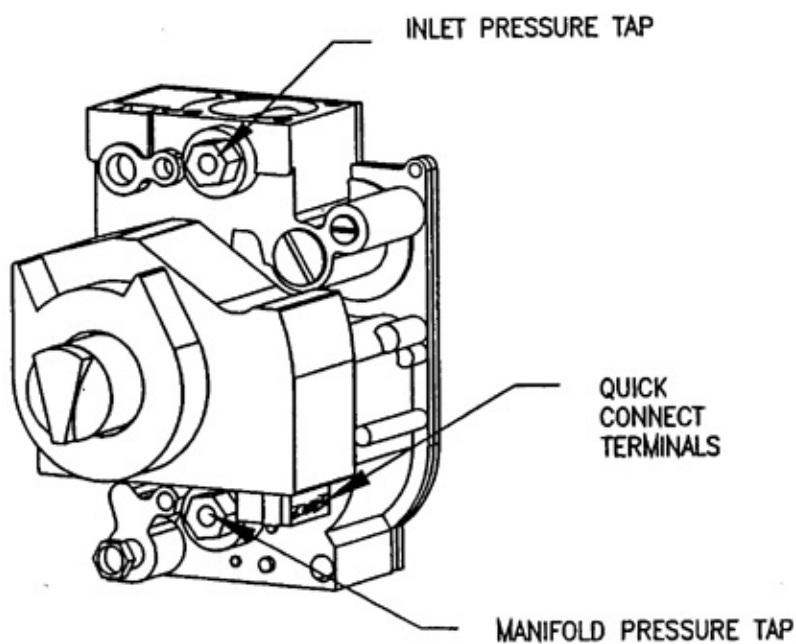

Figure 12

Temperature Control Servicing Procedure

Set the thermostat above water temperature (See temperature adjustment section) and observe system through one (1) complete cycle. Make sure system operates as desired.

To check the thermistor or thermistor/ECO assembly, compare the resistance of the sensor terminals (blue leads) as measured by an ohmmeter to the water temperature as measured by an accurate thermometer. Thermistor resistance increases as the temperature decreases. The tables below show the correct sensor resistance at various temperatures.

In Degrees F										
*F	0	1	2	3	4	5	6	7	8	9
40	26109	25400	24712	24045	23399	22771	22163	21573	21000	20445
50	19906	19383	18876	18383	17905	17440	16990	16553	16128	15715
60	15314	14925	14548	14180	13823	13477	13140	12812	12494	12185
70	11884	11592	11308	11032	10763	10502	10248	10000	9760	9526
80	9299	9078	8862	8653	8449	8250	8057	7869	7685	7507
90	7333	7165	7000	6839	6683	6531	6383	6238	6098	5961
100	5827	5697	5570	5446	5326	5208	5094	4982	4873	4767
110	4663	4562	4464	4368	4274	4183	4094	4006	3922	3839
120	3758	3679	3602	3527	3453	3382	3312	3244	3177	3112
130	3048	2986	2925	2866	2808	2752	2697	2643	2590	2538
140	2488	2439	2391	2344	2298	2253	2209	2166	2124	2083
150	2043	2004	1966	1928	1891	1856	1820	1786	1753	1720
160	1688	1656	1625	1595	1566	1567	1509	1481	1454	1427
170	1402	1376	1351	1327	1303	1280	1267	1235	1213	1191
180	1170	1150	1129	1110	1090	1071	1053	1035	1017	999
190	982	965	949	933	917	901	886	871	857	842
200	828	814	801	788	776	762	749	737	725	713

In Degrees C										
*C	0	1	2	3	4	5	6	7	8	9
0	32648	31026	29495	28049	26682	25389	24166	23010	21915	20879
10	19898	18968	18086	17253	16481	15710	14998	14322	13680	13071
20	12492	11942	11419	10922	10450	10000	9672	9165	8778	8409
30	8057	7722	7403	7099	6808	6532	6268	6016	5775	5546
40	5327	5117	4917	4726	4543	4368	4201	4042	3889	3742
50	3602	3468	3340	3217	3099	2986	2878	2774	2675	2579
60	2488	2400	2316	2236	2157	2083	2011	1942	1876	1813
70	1752	1693	1637	1582	1530	1480	1432	1385	1340	1297
80	1266	1216	1177	1140	1105	1070	1037	1005	974	944
90	916	888	861	835	810	788	763	741	719	698

WATER HEATER PARTS LIST DRAWING

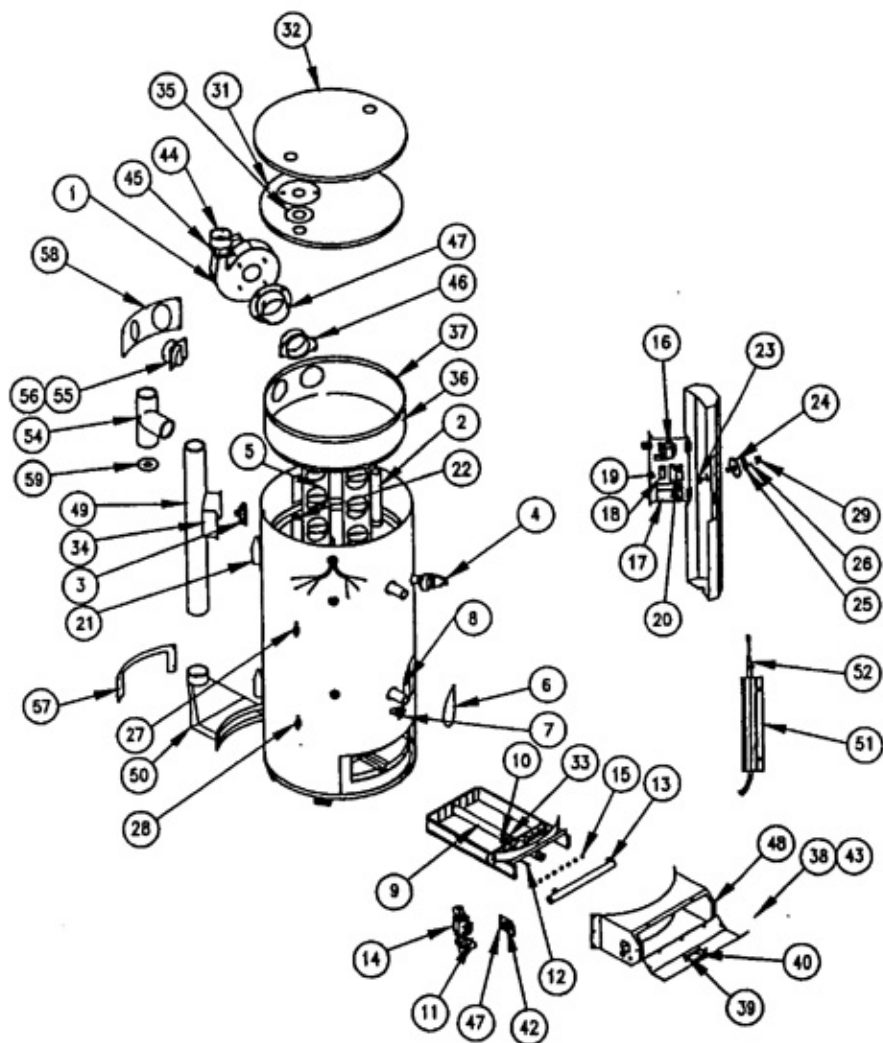

WATER HEATER PARTS LIST

PART NAME AND DESCRIPTION	
1. Induced Draft Blower Assembly	30. Pressure Switch Tubing (Not Shown – 2 pcs)
2. Diptube	31. Flue Collector Head
3. Pressure Switch	32. Jacket Head
4. T&P Valve	33. Pilot Shield
5. Flue Baffle	34. Pressure Switch Cover
6. Cleanout Access (Jacket) Cover	35. Collector Nipple Gaskets (2)
7. Drain Valve	36. Flue Collector
8a. Cleanout Cover	37. Flue Collector Gasket (Top Edge)
8b. Cleanout Cover O-Ring (under cover – not shown)	38. Burner Access Cover Gasket
9. Main Burner Tubes	39. Sight Glass Gasket
10. Pilot Assembly	40. Sight Glass
11. Pilot Supply Tube (Control Side)	41. Tank (Not shown)
12. Pilot Supply Tube (Burner Side)	42. Manifold Flange
13. Main Burner Manifold	43. Burner Access Cover
14. Gas Valve	44. Blower Outlet Connection
15. Main Burner Orifice	45. Blower Outlet Flange Gasket
16. Transformer	46. Collector to Blower Transition
17. Ignition Module	47. Blower Mounting Flange w/ Pressure Tap
18. Terminal Block	48. Front Combustion Box Assy
19. On-Off Switch	49. Combustion Air Tube
20. Thermostat Board	50. Combustion Air Inlet Boot
21. Utility Cover	51. Wire Raceway
22. Outlet Nipple	52. Gas Valve Wire Harness
23. Temperature Control Potentiometer	53. Vent Safety Switch (Not Shown – Located Below Blower Outlet Flange)
24. Gasket - Potentiometer	54. Dilution Air Tee
25. Bezel - Temperature Control	55. Dilution Air Inlet
26. Screw - Bezel Position	56. Dilution Air Pressure Tap
27. Upper Temperature Sensor	57. Escutcheon – Rear Boot
28. Lower Temperature Sensor	58. Blower Escutcheon
29. Temperature Control Knob	59. Combustion Air Orifice (Inside Dilution Air Tee)
	60. Anode Rods (4) (Not shown – top of tank)

VENT KIT COMPONENTS AND OPTIONAL CONDENSATE TEE

150,00 AND 199,999 BTU/HR. MODELS: 3" VENT KIT

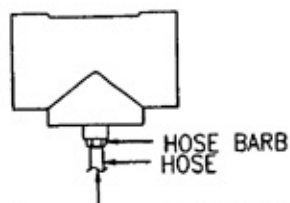
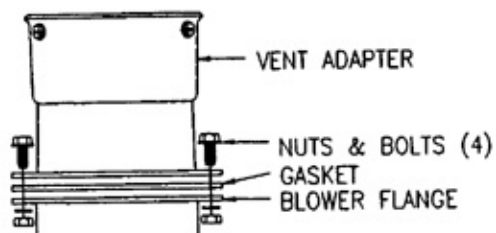

OPTIONAL 3" CONDENSATE DRAIN TEE
NOTE BARB FITTING ON DRAIN TEE
FITS 3/8" FLEXIBLE PLASTIC TUBING

MODELS OVER 200,000 BTU/HR.: 4" VENT KIT

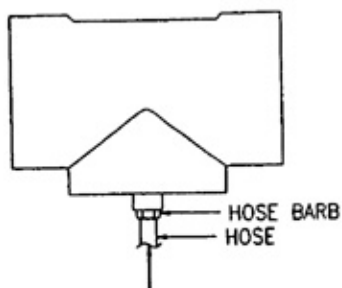
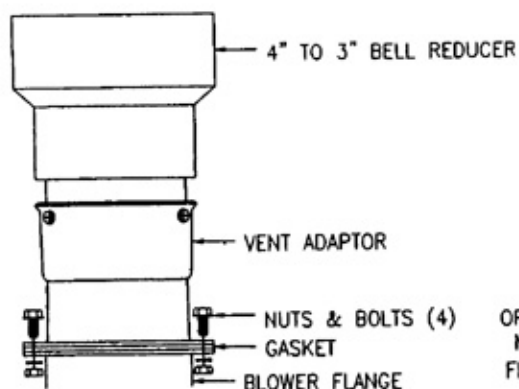

OPTIONAL 4" CONDENSATE DRAIN TEE
NOTE BARB FITTING ON DRAIN TEE
FITS 3/8" FLEXIBLE PLASTIC TUBING

COMMON: 3" AND 4" VENT KIT

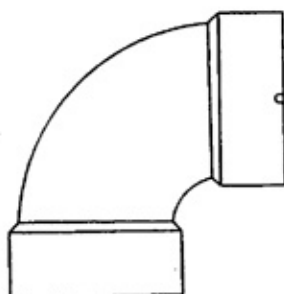

3" OR 4" EXHAUST TERMINAL

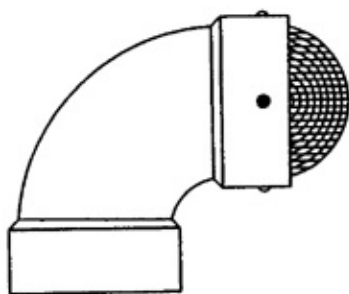

3" OR 4" INTAKE TERMINAL

THE FOLLOWING INSTRUCTIONS ARE FOR INSTALLATION OF: GAS WATER HEATERS SUITABLE FOR WATER (POTABLE) HEATING AND SPACE HEATING

1. All piping components connected to this water heater for space-heating applications must be suitable for use with potable water.
2. Toxic chemicals, such as those used for boiler treatment, **must not** be introduced into potable water used for space heating.
3. This water heater **must not** be connected to an existing heating system or component(s) previously used with a non-potable water heating appliance.
4. When the system requires water for space heating at temperatures higher than required for other uses, a tempering valve must be installed to temper the water for those uses in order to reduce the scald hazard potential.

Please refer to the illustrations below and on the following pages for suggested piping arrangements.

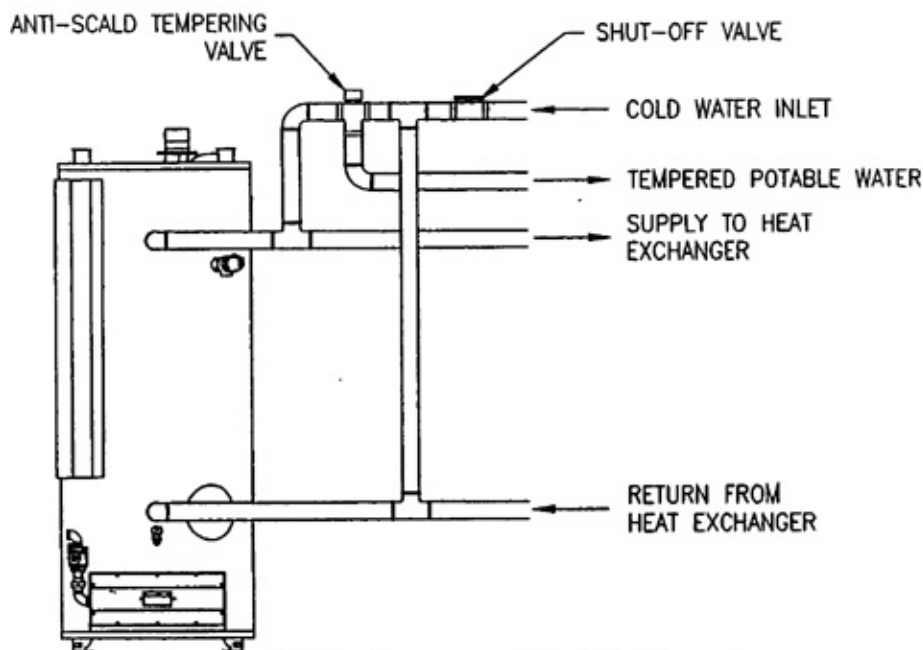

Suggested Piping Arrangement For Side Connections

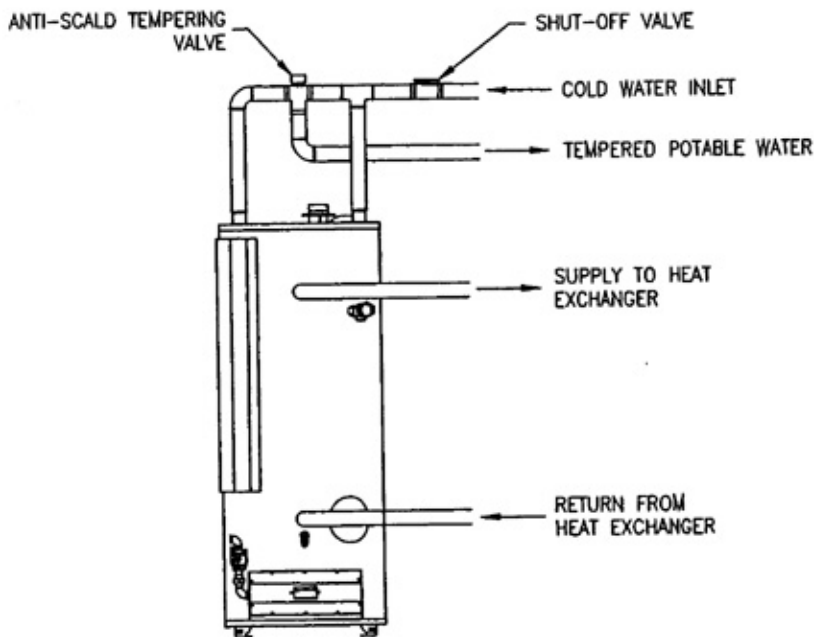

Suggested Piping Arrangement For Top and Side Connections

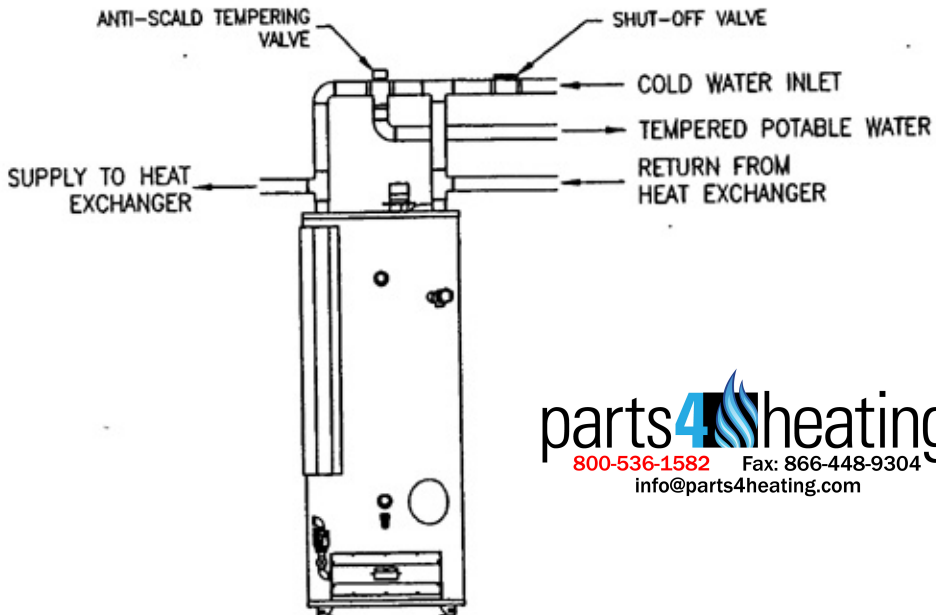

Suggested Piping Arrangement For Top Connections

parts4heating
 800-536-1582 Fax: 866-448-9304
 info@parts4heating.com