

Installation,
Operation and
Maintenance
Instructions for

Mighty Max

Hydronic Boilers

Model HH

Sizes 320M - 1000M

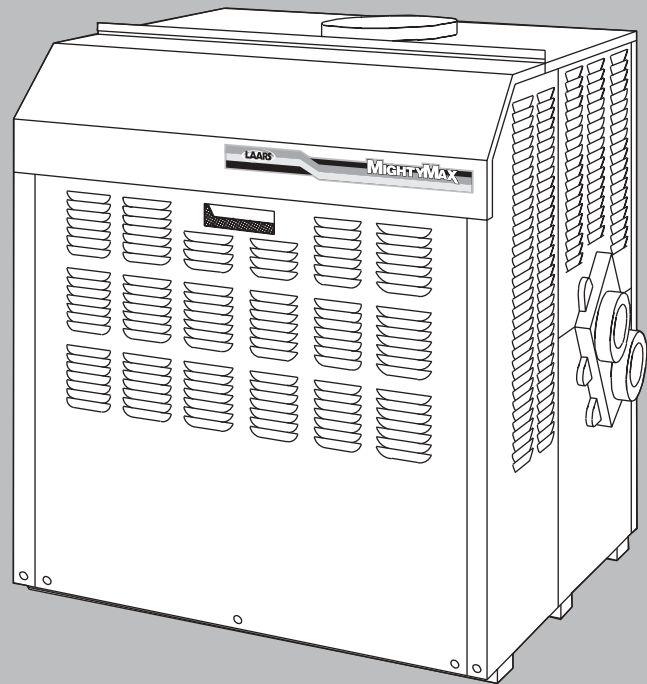

FOR YOUR SAFETY: This product must be installed and serviced by a professional service technician, qualified in hot water boiler installation and maintenance. Improper installation and/or operation could create carbon monoxide gas in flue gases which could cause serious injury, property damage, or death. Improper installation and/or operation will void the warranty.

⚠️ WARNING

If the information in this manual is not followed exactly, a fire or explosion may result causing property damage, personal injury or loss of life.

Do not store or use gasoline or other flammable vapors and liquids in the vicinity of this or any other appliance.

WHAT TO DO IF YOU SMELL GAS

- Do not try to light any appliance.
- Do not touch any electrical switch; do not use any phone in your building.
- Immediately call your gas supplier from a nearby phone. Follow the gas supplier's instructions.
- If you cannot reach your gas supplier, call the fire department.

Installation and service must be performed by a qualified installer, service agency, or gas supplier.

⚠️ AVERTISSEMENT

Assurez-vous de bien suivre les instructions données dans cette notice pour réduire au minimum le risque d'incendie ou d'explosion ou pour éviter tout dommage matériel, toute blessure ou la mort.

Ne pas entreposer ni utiliser d'essence ni d'autres vapeurs ou liquides inflammables dans le voisinage de cet appareil ou de tout autre appareil.

QUE FAIRE SI VOUS SENTEZ UNE ODEUR DE GAZ:

- Ne pas tenter d'allumer d'appareils.
- Ne touchez à aucun interrupteur. Ne pas vous servir des téléphones dans le bâtiment où vous vous trouvez.
- Appelez immédiatement votre fournisseur de gaz depuis un voisin. Suivez les instructions du fournisseur.
- Si vous ne pouvez rejoindre le fournisseur de gaz, appelez le service des incendies.

L'installation et l'entretien doivent être assurés par un installateur ou un service d'entretien qualifié ou par le fournisseur de gaz.

TABLE OF CONTENTS

SECTION 1.

General Information

1A. Introduction 3
 1B. Warranty 3
 1C. Technical Assistance 3

SECTION 2.

Installation Instructions

2A. General Information 4
 2B. Boiler Placement 4
 2C. Installation of Outdoor Boilers 4
 2D. Freeze Protection 4
 2E. Installation of Indoor Boilers 5
 2E-1. Combustion Air Supply and Ventilation 5
 2E-2. Removal of Existing Boiler 5
 2F. Gas Supply and Piping 6
 2G. Water System Requirements 8
 2G-1. Flow Requirements 8
 2G-2. Variable Water Flow Systems 8
 2G-3. System Pressure Requirements 9
 2G-4. Hot/Chilled Water Systems 9
 2G-5. Combined Space Heating/Potable
 Water Heating Systems 9
 2H. Piping of System to Boiler 9
 2I. Filling the System 10
 2J. Venting and Combustion Air Information 10
 2K. Top-to-Rear Vent Collar Conversion 12
 2L. Venting 13
 2L-1. Vertical Venting - Category I 13
 2L-2. Vertical Venting - Non Category I 13
 2L-3. Vertical Venting - Non Category 1 13
 2L-4. Side Wall Vent Terminal 14
 2M. Air for Combustion and Ventilation 14
 2M-1. Air From Room 15
 2M-2. Ducted Combustion Air 15
 2M-3. Conversion for Ducted
 Combustion Air 15
 2M-4. Combustion Air Piping 16
 2N. Electrical Wiring 16

SECTION 3.

Operating Instructions

3A. Start Up Requirements 16
 3B. Hi-Limit checkout 18
 3C. Venturi and Gas Pressure
 Regulator System 18
 3C-1. Overall Operation 18
 3C-2. Venturi Adjustment 18
 3D. To Start Up System 19
 3D-1. Setting Temperature Controls 20
 3E. To Shut Down System 20
 3F. Venturi Combustion Flow System 20
 3F-1. Pressure Measurement Ports 20
 3F-2. Venturi Adjustment 20
 3F-3. Venturi Setup Procedure 22

SECTION 4.

Maintenance

4A. General Instructions 22
 4B. Heat Exchanger 22
 4B-1. Inspection of the Heat Exchanger 23
 4B-1a. External heat Exchanger Inspection 23
 4B-1b. Internal Heat Exchanger Inspection 23
 4B-2. Cleaning the Heat Exchanger 23
 4B-2a. Cleaning the Heat Exchanger - External 23
 4B-2b. Cleaning the Heat Exchanger - Internal 23
 4C. Gas and Electric Controls 23
 4D. Filter 24
 4D-1. Filter Function 24
 4D-2. Filter Service 24

SECTION 5.

Troubleshooting

5A. Sequence of Operation 24
 5B. Venturi and Gas Pressure
 Regulator System 26
 5B-1. Field Checkout 26
 5C. Electrical Components 26
 5C-1. General Troubleshooting 26
 5C-2. Electrical Troubleshooting 26

SECTION 6.

Parts List for Mighty Max HH Boiler

6A. General Information 27

SECTION 1. General Information

1A. Introduction

This manual contains installation, operation and maintenance instruction for the Mighty Max hydronic boiler, Model HH, sizes 320M, 400M, 520M, 625M, 775M and 1000M. Review all application and installation procedures completely before proceeding with the installation. Consult the local factory representative or Laars factory with any questions regarding this equipment. Experience has shown that most operating problems are caused by improper installation. The HH boilers are offered in an indoor version and an outdoor version (see Figure 1). Table 1 lists the input/output ratings for each boiler size.

The indoor version is convertible for outdoor use with the installation of a conversion kit. See Section 6, Parts List, for part number.

1B. Warranty

The Mighty Max HH boilers are sold with a limited factory warranty. Details are specified on the back cover of this manual.

Make all warranty claims to an authorized Laars representative or directly to the factory. Claims must include the heater serial number and model number (this information can be found on the rating plate), installation date, and name of the installer. Shipping costs are not included in the warranty coverage.

Some accessory items are shipped in separate packages. Inspect everything for damage immediately upon delivery, and advise the transporter of any shortages or damage. Any such claims should be filed with the transporter. The transporter will not accept a claim from the shipper, Laars.

The warranty does not cover damage caused by improper installation, operation, or field modification.

1C. Technical Assistance

Consult the local factory representative or Laars factory with any questions regarding the specification, installation, and operation of Laars equipment. An experienced technical support staff is ready to assist in assuring the proper performance and application of Laars products.

| Boiler Size | Input | | Output | |
|-------------|-----------|-----|---------|-----|
| | BTU/h | kW | BTU/h | kW |
| 320M | 320,000 | 94 | 272,000 | 80 |
| 400M | 399,000 | 117 | 339,150 | 99 |
| 520M | 520,000 | 152 | 442,000 | 130 |
| 625M | 625,000 | 183 | 531,250 | 156 |
| 775M | 775,000 | 227 | 658,750 | 193 |
| 1000M | 1,000,000 | 293 | 850,000 | 249 |

Table 1. Input/Output Ratings.

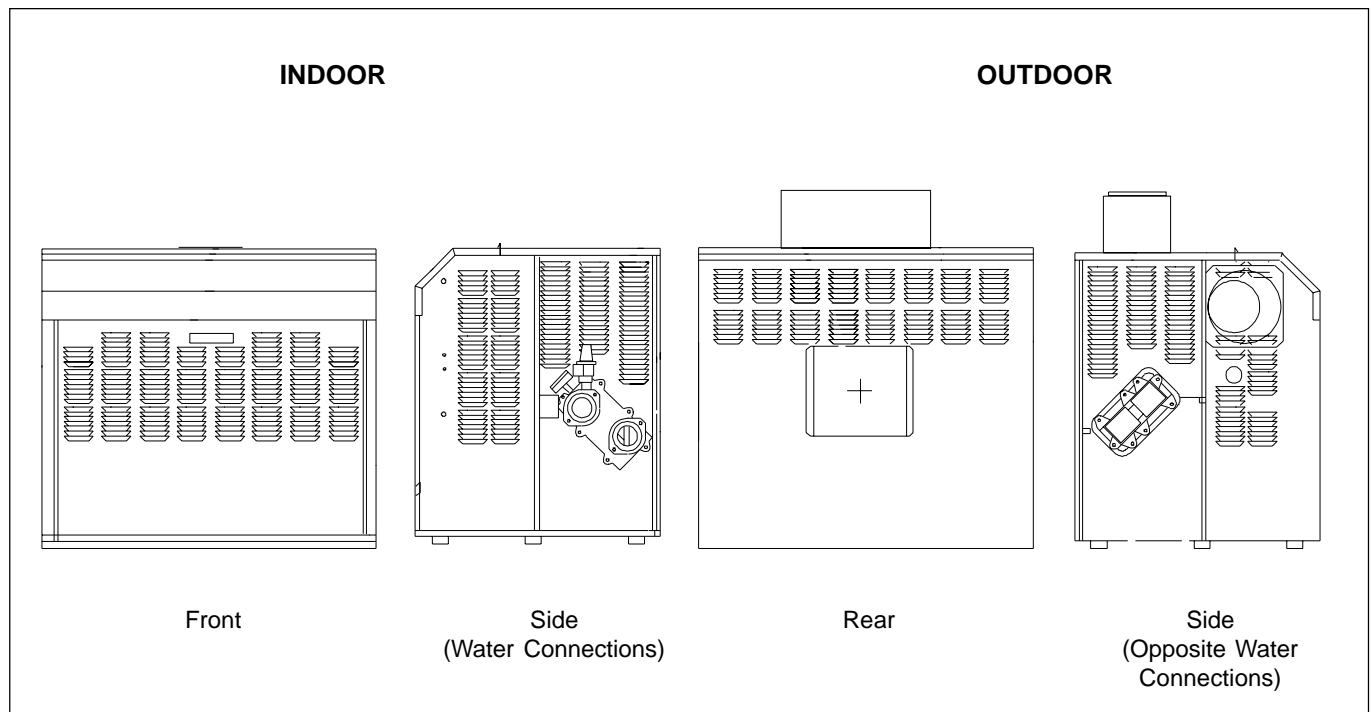

Figure 1. Mighty Max HH Boiler Configuration.

SECTION 2. Installation Instructions

2A. General Information

Install the Mighty Max HH boiler in accordance with the procedures in this manual (or the Laars warranty may be voided), local codes, and ordinances. In the absence of such codes, install the heaters in accordance with the latest edition of the National Fuel Gas Code, ANSI Z223.1/National Fire Protection Association (NFPA) 54. In Canada, the installation must be in accordance with CAN1-B149.1 or .2 and local codes. The authority having jurisdiction may require the installation be in accordance with the American Society of Mechanical Engineers (ASME) Safety Codes for Controls and Safety Devices for Automatically Fired Heaters, CSD-1, and in Canada, Canadian Gas Association (CGA) 3.3. Any changes to the boiler, its gas controls, gas orifices or wiring may void the warranty. If field conditions require change, consult the factory.

The Mighty Max HH boiler is designed-certified for installation on a combustible floor. **Do not install the boiler directly on carpeting.**

2B. Boiler Placement

| Clearance From Combustibles | Indoor Inches mm | Outdoor Inches mm |
|-----------------------------|---------------------|----------------------|
| Top | 18 457 | Unobstructed |
| Water Conn. Side | 12 305 | 12 305 |
| Opposite Side | 6 152 | 6 152 |
| Front | Alcove | Unobstructed |
| Rear | 6 152 | 6 152 |
| Vent | *6 152 | — |
| Flooring | Combustible | Combustible |

Service clearance = 24 in. (610mm) at front of boiler.
*1 in. (25mm) if double wall vent is used.

Table 2. Minimum Boiler Clearances from Combustible Surfaces.

Locate the boiler to provide adequate clearances on all sides for maintenance and inspection. There must also be minimum distances maintained from combustible surfaces (See Table 2).

The boiler must be isolated or otherwise protected from any source of corrosive chemical fumes, such as trichlorethylene, perchlorethylene, chlorine, etc. Install the boiler so that the gas ignition system components are protected from water (drippings, spraying, rain, etc.) during operation and service.

2C. Installation of Outdoor Boilers

⚠ Caution

Outdoor installations are not recommended in areas where the danger of snow blockage exists.

1. Locate the boiler to provide at least the minimum clearances as listed in Section 2B, "Boiler Placement." HH boilers require an outdoor terminal kit when installed outdoors (see Section 6, Parts List).
2. Do not locate the boiler in an enclosure or through-wall recess. Avoid locations where wind deflection off structures might cause down-draft. When such wind conditions are possible, locate the boiler at least 3 feet (.9m) from structures.
3. Never install the boiler under any kind of roof overhang. Do not locate the boiler below or adjacent to any doors, windows, louvers, grills, etc. which communicate in any way with an inhabited area of a building, even though such communication might be through another structure such as a garage or utility room (see Figure 2).

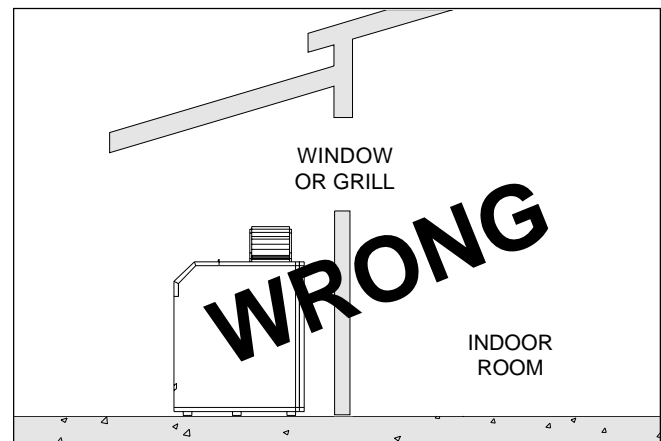

Figure 2. Incorrect Installation of Boiler.

2D. Freeze Protection

Boiler installations are not recommended in areas where the danger of freezing exists unless proper precautions are made for freeze protection. Maintaining a mixture of 50% water and 50% properly inhibited HVAC glycol is the preferred method of freeze protection for hydronic systems. (Do not use automotive antifreeze.) This mixture will protect the boiler to temperatures of about -35°F (-37°C). To get the desired temperature rise across the boiler when this mixture is used, increase the water flow recommendation by 15%. Increase the head loss requirement by 20%. Note: If your application does

not require the full freeze protection of a 50%/50% mixture, it is beneficial to use a maximum 30% glycol solution. This mixture will protect the boiler to temperatures of about 5°F (-15°C), and will serve as burst protection for boilers that are not in use.

2E. Installation of Indoor Boilers

2E-1. Combustion Air Supply and Ventilation

There are a variety of options available to the installer when it comes to venting and combustion air; venting can be vertical or horizontal, it can originate at the top of the boiler or the back, and combustion air can be obtained from the room where the boiler is installed or ducted directly to the boiler from outdoors. See Sections 2J through 2M for details.

2E-2. Removal of Existing Boiler

At the time of removal of an existing boiler, the following steps shall be followed with each appliance remaining connected to the common venting system placed in operation, while the other appliances remaining connected to the common venting system are not in operation.

1. Seal any unused openings in the common venting system.
2. Visually inspect the venting system for proper size and horizontal pitch and determine there is no blockage or restriction, leakage, corrosion and other deficiencies which could cause an unsafe condition.
3. Insofar as is practical, close all building doors and windows, and all doors between the space in which the appliances remaining connected to the common venting system are located and other spaces of the building. Turn on clothes dryers and any appliance not connected to the common venting system. Turn on any exhaust fans, such as range hoods and bathroom exhausts so they will operate at maximum speed. Do not operate a summer exhaust fan. Close fireplace dampers.
4. Place in operation the appliance being inspected. Follow the lighting instructions. Adjust thermostat so appliance will operate continuously.
5. Test for spillage at the draft hood relief opening if the appliance is equipped with a draft hood, after 5 minutes of main burner operation. Use the flame of a match or candle, or smoke from a cigarette, cigar or pipe.
6. After it has been determined that each appliance remaining connected to the common venting system properly vents when tested as outlined above, return door, windows, exhaust fans,

fireplace dampers and any other gas-burning appliances to their previous condition of use.

7. Any improper operation of the common venting system should be corrected so the installation conforms with the National Fuel Gas Code, ANSI Z223.1. When resizing any portion of the common venting system, the common venting system should be resized to approach the minimum size as determined using the appropriate Tables in Appendix G in the National Fuel Gas Code, ANSI Z223.1.

In Canada, at the time the boiler is removed from common venting system, the common venting system should be resized so the installation conforms to CAN/CGA B149.1 or .2.

2E-2. Removal of Existing Boiler

Au moment du retrait d'une chaudière existante, les mesures suivantes doivent être prises pour chaque appareil toujours raccordé au système d'évacuation commun et qui fonctionne alors que d'autres appareils toujours raccordés au système d'évacuation ne fonctionnent pas:

1. Sceller toutes les ouvertures non utilisées du système d'évacuation.
2. Inspecter de façon visuelle le système d'évacuation pour déterminer la grosseur et l'inclinaison horizontale qui conviennent et s'assurer que le système est exempt d'obstruction, d'étranglement, de fuite, de corrosion et autres défaillances qui pourraient présenter des risques.
3. Dans la mesure du possible, fermer toutes les portes et les fenêtres du bâtiment et toutes les portes entre l'espace, où les appareils toujours raccordés et les autres espaces du bâtiment. Mettre en marche les sècheuses, tous les appareils non raccordés au système d'évacuation commun et tous les ventilateurs d'extraction comme les hottes de cuisinière et les ventilateurs des salles de bain. S'assurer que ces ventilateurs fonctionnent à la vitesse maximale, Ne pas faire fonctionner les ventilateurs d'été. Fermer les registres des cheminées.
4. Mettre l'appareil inspecté en marche. Suivre les instructions d'allumage. Régler le thermostat de façon continue.
5. Faire fonctionner le brûleur principal pendant 5 min ensuite déterminer si le coupe-tirage déborde à l'ouverture de décharge. Utiliser la flamme d'une allumette ou d'une chandelle ou la fumée d'une cigarette, d'un cigare ou d'une pipe.
6. Une fois qu'il a été déterminé, selon la méthode indiquée ci-dessus, que chaque appareil raccordé

| Size | Distance from Gas Meter or Last Stage Regulator | | | | | | | | | | | |
|-------|-------------------------------------------------|----|---------|----|------------------------|----|---------|----|------------------------|----|---------|----|
| | 0-100 feet 0-30m | | | | 100-200 feet 30-60m | | | | 200-300 feet 60-90m | | | |
| | Natural | | Propane | | Natural | | Propane | | Natural | | Propane | |
| | in. | mm | in. | mm | in. | mm | in. | mm | in. | mm | in. | mm |
| 320M | 1.25 | 32 | 1.25 | 32 | 1.50 | 38 | 1.25 | 32 | 1.50 | 38 | 1.50 | 38 |
| 400M | 1.25 | 32 | 1.25 | 32 | 1.50 | 38 | 1.25 | 32 | 2.00 | 51 | 1.50 | 38 |
| 520M | 1.50 | 38 | 1.25 | 32 | 2.00 | 51 | 1.50 | 38 | 2.00 | 51 | 1.50 | 38 |
| 625M | 1.50 | 38 | 1.25 | 32 | 2.00 | 51 | 1.50 | 38 | 2.00 | 51 | 2.00 | 51 |
| 775M | 2.00 | 51 | 1.50 | 38 | 2.00 | 51 | 1.50 | 38 | 2.50 | 64 | 2.00 | 51 |
| 1000M | 2.00 | 51 | 1.50 | 38 | 2.50 | 64 | 2.00 | 51 | 3.00 | 76 | 2.50 | 64 |

Notes: 1. These numbers are based on 1/2 inch (13mm) water column pressure drop.
2. Check supply pressure and local code requirements before proceeding with work.
3. Pipe fittings must be considered when determining gas pipe sizing.

Table 3. Natural Gas and Propane, Pipe Size Requirements.

au système d'évacuation est mis à l'air libre de façon adéquate. Remettre les portes et les fenêtres, les ventilateurs, les registres de cheminées et les appareils au gaz à leur position originale.

7. Tout mauvais fonctionnement du système d'évacuation commun devrait être corrigé de façon que l'installation soit conforme au *National Fuel Gas Code, ANSI Z223.1/NFPA 54* et (ou) aux codes d'installation *CAN/CGA-B149*. Si la grosseur d'une section du système devrait être modifiée pour respecter les valeurs minimales des tableaux pertinents de l'appendice F du *National Fuel Gas Code, ANSI Z223.1/NFPA 54* et (ou) des codes d'installation *CAN/CGA-B149*.

2F. Gas Supply and Piping

Review the following instructions before continuing the installation.

- Gas piping installation must be in accordance with the latest edition of ANSI Z223.1/NFPA 54. In Canada, the installation must be in accordance with CAN1-B149.1 or .2 and all local codes that apply. See Figure 3 for boiler gas valve arrangement.
- Check the rating plate to make sure the boiler is fitted for the type of gas being used. Laars boilers are normally equipped to operate below a 2000 foot (610m) altitude. Boilers equipped to

operate at high altitudes have appropriate stickers or tags attached.

- The figures in Table 3 should be used to size the gas piping from the gas meter to the boiler. Check local codes for BTU/h capacity required.
- Install a sediment trap (drip leg) ahead of the gas controls (see Figure 4). Fit the trap with a threaded cap which can be removed for cleaning.
- When required by code, install a second manual gas shutoff valve. Do not remove manual shutoff valve supplied with the boiler.
- Disconnect the boiler and its individual shutoff valve from the gas supply piping system during pressure testing of the system at pressures higher than 1/2 psi (3.5 kPa). Isolate the boiler from the gas supply piping system by closing its individual manual gas shutoff valve during any pressure testing of the gas supply piping system at test pressures equal to or less than 1/2 psi (3.5 kPa).
- Gas supply pressures to the boiler are listed in Table 4.

| Supply Pressure Water Column | Natural Gas | | Propane Gas | |
|---------------------------------|-------------|-----|-------------|-----|
| | in. | mm | in. | mm |
| Minimum | 5 | 127 | 9 | 229 |
| Maximum | 9 | 229 | 14 | 356 |

Table 4. Gas Supply Pressure Requirements.

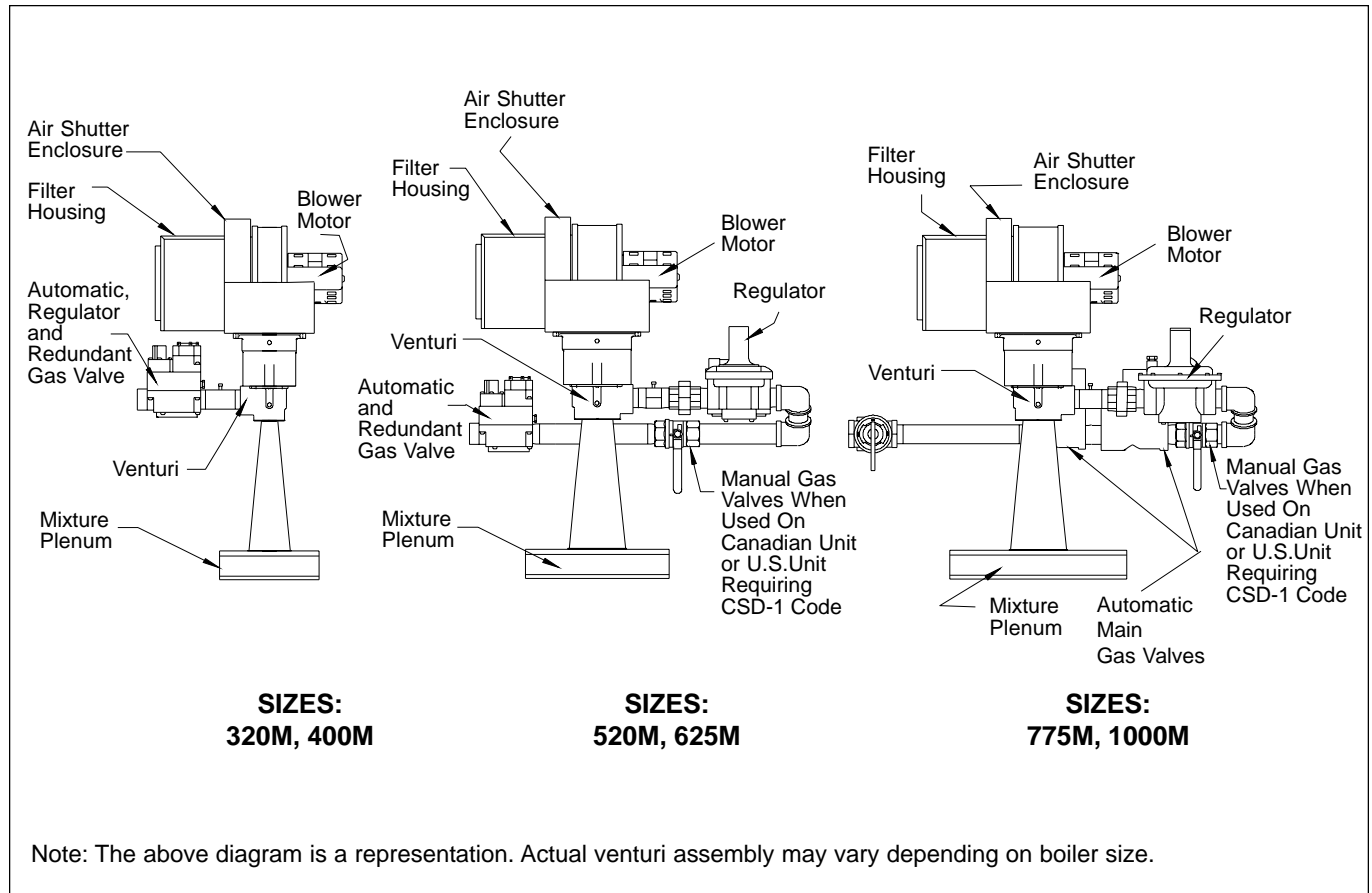

Figure 3. Boiler Gas Valve Arrangement.

NOTE: The boiler and all other gas appliances sharing the boiler gas supply line must be firing at maximum capacity to properly measure the inlet supply pressure. Low gas pressure could be an indication of an undersize gas meter and/or obstructed gas supply line.

8. Do not exceed the maximum inlet gas pressures specified. Excessive pressure will result in damage to the heater's gas controls. The minimum pressures specified are for gas input adjustment.
9. The correct differential gas pressure is stamped on the rating plate. The regulator is preset at the factory, but may need adjustment for altitude per Section 3.
10. Before operating the heater, test the complete gas supply system and all connections for leaks using a soap solution.

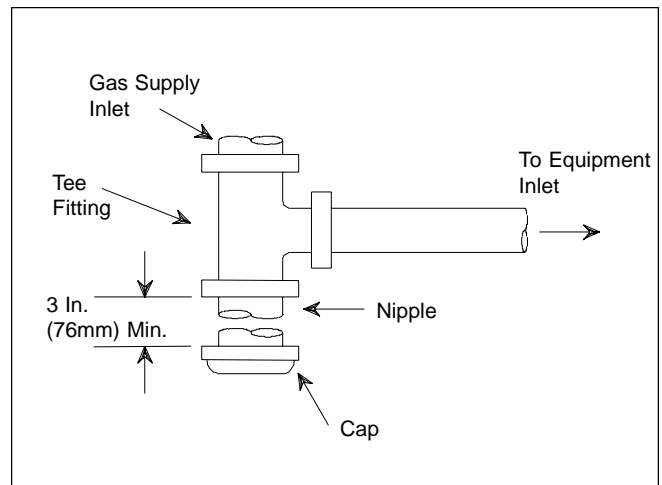

Figure 4. T-Fitting Sediment Trap Installation.

⚠ Caution

Since some leak test solutions (including soap and water) may cause corrosion or stress cracking, rinse the piping with water after testing.

2G. Water System Requirements

2G-1. Flow Requirements

The Model HH boilers must have continuous flow through the heat exchanger when firing for proper operation. The system pump must be capable of developing sufficient pressure to overcome the resistance of the boiler plus the entire circulating system at the designated flow (see Table 5). The temperature rise across the boiler should never exceed 40°F (22°C).

2G-2. Variable Water Flow Systems

There can be reduced water flow through the boiler in heating systems using zone valves, zone pumps or 3-way valves. This can result in a high temperature rise across the boiler. Laars recommends primary-secondary pumping for all variable flow systems. The boiler pump in a primary-secondary system maintains constant flow through the boiler even though the system flow is variable. In a primary-secondary system the pressure drop of the boiler is not added to the system (see Figure 5).

TEMPERATURE RISE IN DEGREES (°F / °C)

| MODEL | 10°F | | 6°C | | 15°F | | 8°C | | 20°F | | 11°C | |
|---------|------|---------|-------|-------|--------|---------|------|-------|------|---------|------|-------|
| | GPM | H/L ft. | LPS | H/L m | GPM | H/L ft. | LPS | H/L m | GPM | H/L ft. | LPS | H/L m |
| HH0320M | 54 | 11.2 | 3.41 | 3.4 | 36 | 5.0 | 2.27 | 1.5 | 27 | 2.8 | 1.70 | 0.9 |
| HH0400M | 68 | 26.2 | 4.29 | 8.0 | 45 | 11.5 | 2.84 | 3.5 | 34 | 6.6 | 2.15 | 2.0 |
| HH0520M | 88 | 8.9 | 5.55 | 2.7 | 58 | 4.0 | 3.66 | 1.2 | 44 | 2.6 | 2.78 | 0.8 |
| HH0625M | 106 | 12.2 | 6.69 | 3.7 | 70 | 5.7 | 4.42 | 1.7 | 53 | 3.3 | 3.34 | 1.0 |
| HH0775M | 132 | 22.5 | 8.33 | 6.9 | 87 | 9.4 | 5.49 | 2.9 | 65 | 5.2 | 4.10 | 1.6 |
| HH1000M | 170 | 37.3 | 10.73 | 11.4 | 113 | 16.5 | 7.13 | 5.0 | 85 | 9.4 | 5.36 | 2.9 |
| Flow | High | | | | Normal | | | | Low | | | |

NOTES: Sizes 320M and 400M use 4-pass heat exchangers; 520M, 625M and 775M use 2-pass heat exchangers.
 *Pressure drop (head loss) through the boiler, expressed in ft. of H₂O.
 Shaded area is the recommended flow and temperature rise. Minimum inlet temperature is 105°F.

Table 5. Temperature Rise.

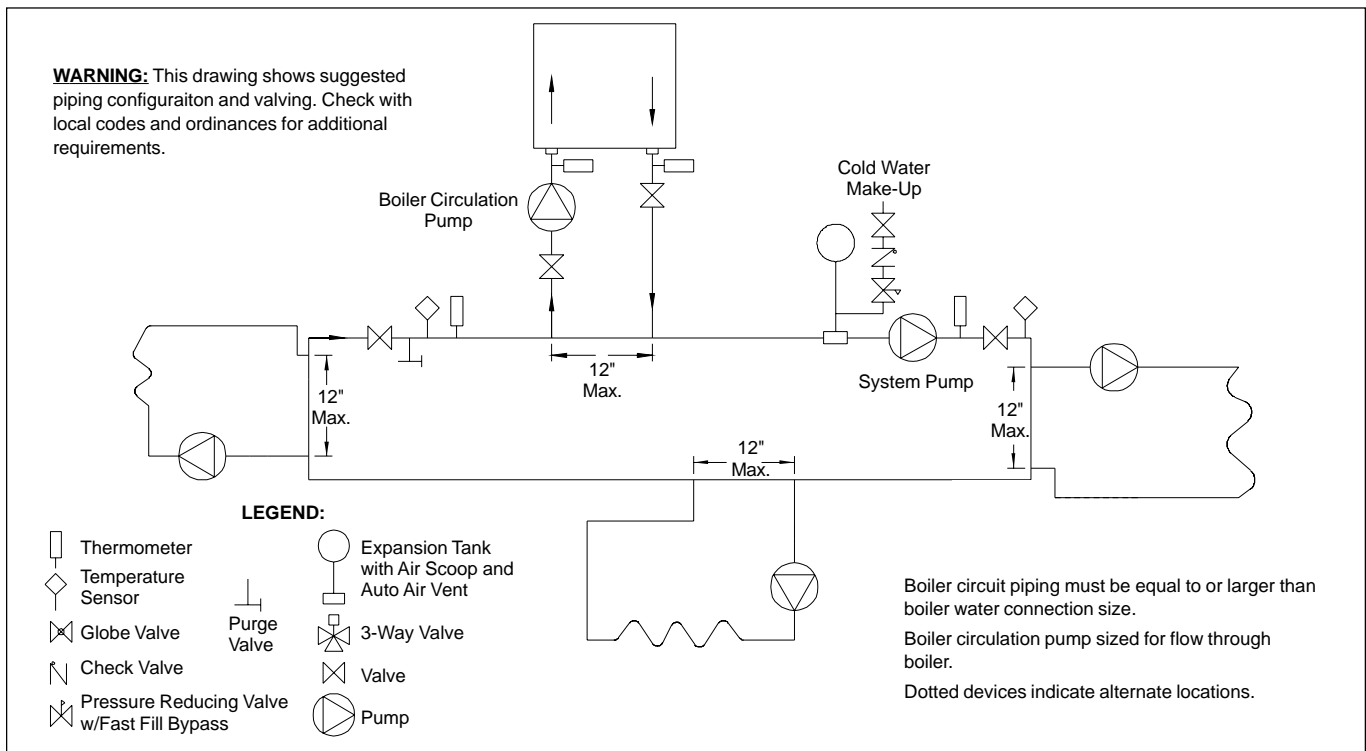

Figure 5. Primary-Secondary Plumbing.

2G-3. System Pressure Requirements

The Model HH boilers are designed to operate on closed, pressurized systems. Maintain a minimum of 12 psi (81.8 kPa) on the system where boiler supply water temperature is 200°F (93°C) or less. If higher temperatures are required, the minimum system pressure should be at least 15 psi (102.2 kPa) above the water vapor pressure corresponding to the elevated water temperature.

The Model HH boilers are not suitable for open systems unless the supply water temperatures are kept below 180°F (82°C), and a minimum of 5 psi (34.1 kPa) static head is maintained at the boiler.

2G-4. Hot/Chilled Water Systems

When a boiler is connected to an air conditioning system where the same water is used for heating and cooling, you must prevent chilled water from entering the boiler. When changing such a system from cooling to heating, allow the chilled water to circulate through the building, after the chiller has been turned off, for a period long enough for the water to warm up to at least 105°F (41°C) before the water flows into the boiler. It is equally important to prevent hot water from entering the chiller. The system shown in Figure 6 is suggested to make sure the system water is neither too hot nor too cold when a changeover takes place. When a boiler is connected to heating coils located in air handling units (where they may be exposed to refrigerated air circulation), install a flow control valve or other automatic means to prevent gravity circulation of chilled water through the boiler. Chilled water in the boiler will create condensate on the boiler tubes.

Boilers installed in violation of the foregoing may void the warranty.

2G-5. Combined Space Heating/Potable Water Heating Systems

When using the Mighty Max boiler as a source of heat for a combined space heating/potable water heating system, be sure to follow the instructions of the space heating system.

Do not use water piping, fittings, valves, pumps, and any other components which are not compatible with potable water.

Do not connect the heater, which will be used to supply potable water, to any heating system or components previously used with a nonpotable water heating system.

Do not add boiler treatment or any chemicals to the heating system piping, since the piping contains water for potable use.

Do not use solder containing lead in the potable water lines.

Some jurisdictions may require a backflow preventer in the cold water line. In such cases,

pressure relief valve may discharge water due to expansion. An expansion tank approved for potable water will eliminate this condition. Follow the manufacturer's instructions for installation of the expansion tank.

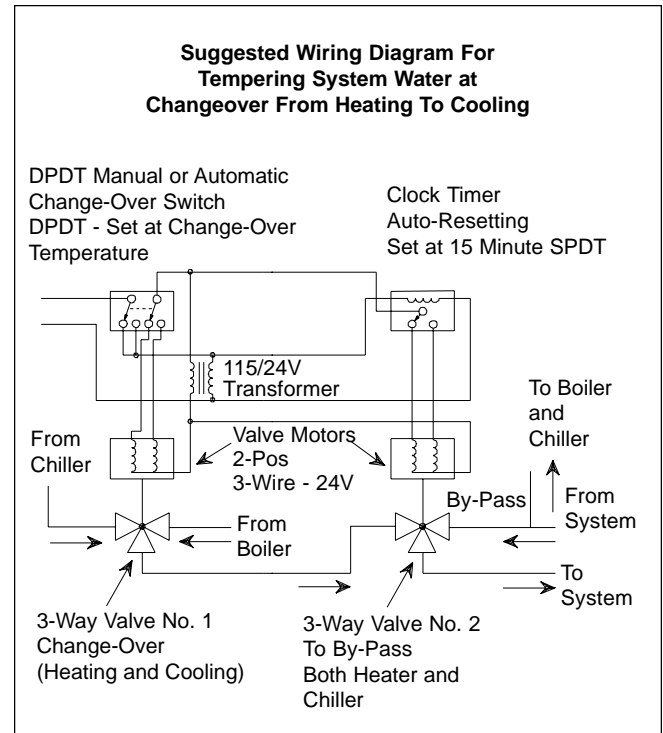

Figure 6. Boiler-Chiller Installation.

2H. Piping of System to Boiler

1. Be sure to provide gate valves at the inlet and outlet to the boiler so it can be readily isolated for service.
2. The pressure relief valve installed in the tapped opening provided in the outlet header must be piped, *but not fastened*, to a drain or floor sink. The drain pipe must be the same size as the valve outlet and must pitch downward from the valve. If the PRV supplied with the boiler is not factory installed, install it in the front header consistent with the ANSI/ASME Boiler and Pressure Vessel Code, Section IV. Pay special attention to relief valve settings in installations where the boiler is located on the ground floor of a tall building, or where the operating temperature of the boiler is above 210°F (99°C). In both instances, the static pressure of the system is elevated and could cause the relief valve to leak and bring considerable raw water into the system. Where no special setting of the relief valve is ordered, the factory will furnish a 75 psi (511.5 kPa) setting. Never reduce the relief valve opening. If necessary, install the relief valve in a Tee immediately past the boiler outlet.

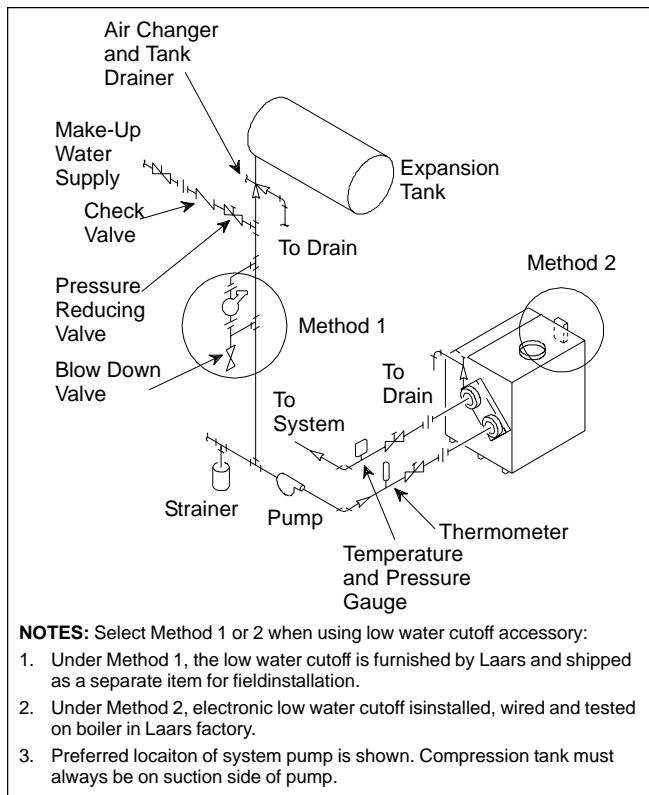

Figure 7. Boiler Piping.

3. Provide a boiler installed above radiation level with a low water cutoff device either as part of the boiler or at the time of boiler installation (see Figure 7).
4. Install manual and/or automatic bleeding devices at high points in the system to eliminate air. Install a correctly sized expansion or compression tank with suitable air charger and tank drainer, as appropriate.
5. Support the weight of all water and gas piping by suitable hangers or floor stands.
6. Check piping diagrams with local applicable plumbing, heating and building safety codes.

2I. Filling The System

1. Ensure the system is fully connected. Close all bleeding devices and open make-up water valve. Allow system to fill slowly.
2. If make-up water pump is employed, adjust pressure switch on pumping system to provide a minimum of 12 psi (81.8 kPa) at the highest point in the heating loop.
3. If a water pressure regulator is provided on the make-up water line, adjust the pressure regulator to provide at least 12 psi (81.8 kPa) at the highest point in the heating loop.
4. Open bleeding devices on all radiation units at the high points in the piping throughout the

system, unless automatic air bleeders are provided at such points.

5. Run system circulating pump for a minimum of 30 minutes with the boiler shut off.
6. Open all strainers in the circulating system, check flow switch operation, and check for debris.
7. Recheck all air bleeders as described in Step 4 above.
8. Check liquid level in expansion tank. With the system full of water and under normal operating pressure, the level of water in the expansion tank should not exceed 1/4 of the total, with the balance filled with air.
9. Start up boiler according to procedure described in Section 3A. Operate the entire system, including the pump, boiler, and radiation units for one (1) hour.
10. Recheck the water level in the expansion tank. If the water level exceeds 1/4 of the volume of the expansion tank, open the tank drainer and drain to that level.
11. Shut down the entire system and vent all radiation units and high points in the system piping as described in Step 4 above.
12. Close make-up water valve and check strainer in pressure reducing valve for sediment or debris from the make-up water line. Reopen make-up water valve.
13. Check gauge for correct water pressure and also check water level in the system. If the height indicated above the boiler insures that water is at the highest point in the circulating loop, then the system is ready for operation.
14. Within three (3) days of start-up, recheck all air bleeders and the expansion tank as described in Steps 4 and 8 above.

IMPORTANT:

The installer is responsible for identifying to the owner/operator the location of all emergency shutoff devices.

2J. Venting and Combustion Air Information

Provisions for venting and supply of air for venting and combustion must be done in accordance with these instructions and applicable requirements of the latest edition of ANSI Z223.1/NFPA 54. In Canada, installation must be in accordance with CAN/CGA B149.1 or .2, and applicable local codes.

There are a variety of ways to provide venting and combustion air for the boiler (see Figure 8).

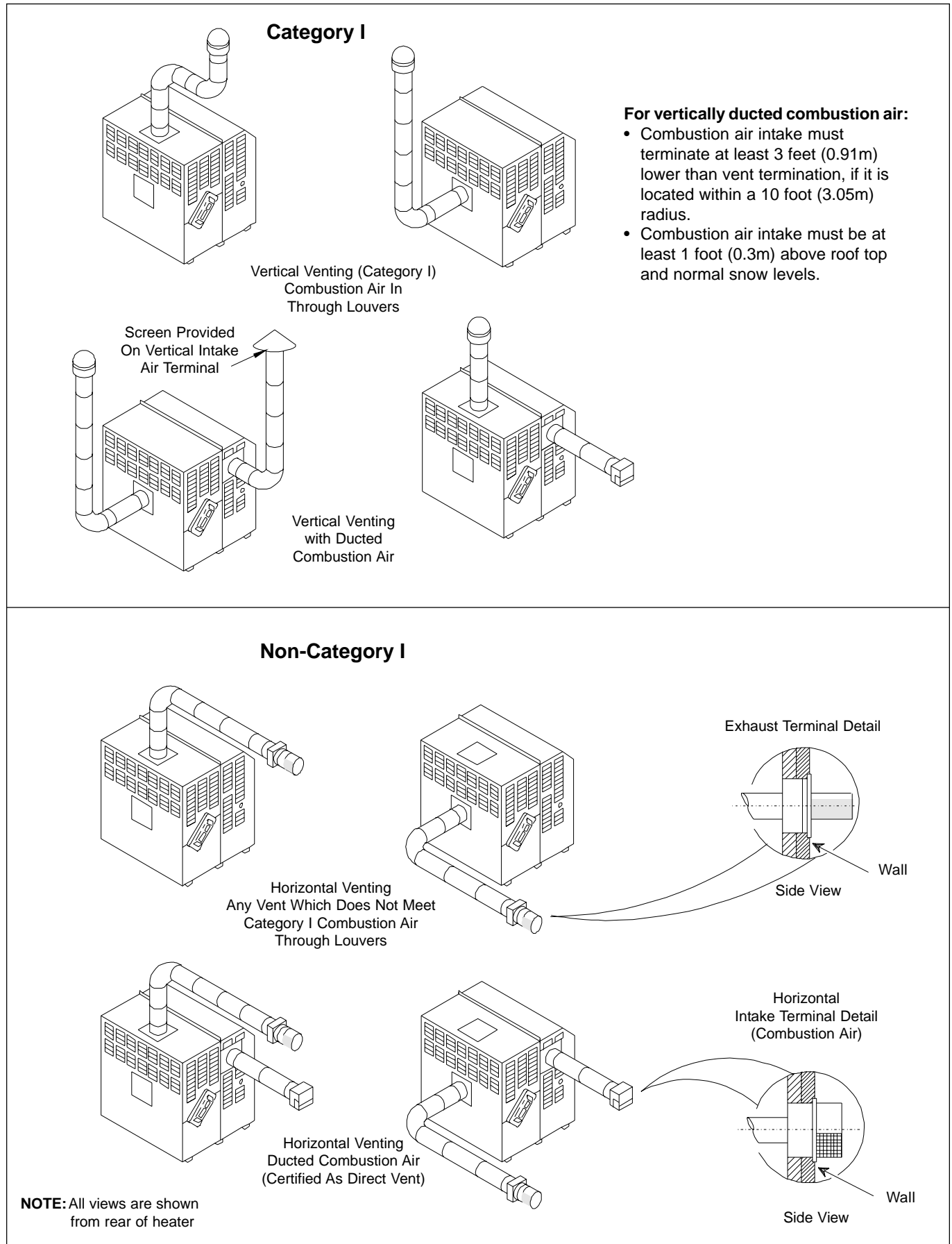

Figure 8. Venting and Combustion Air Options.

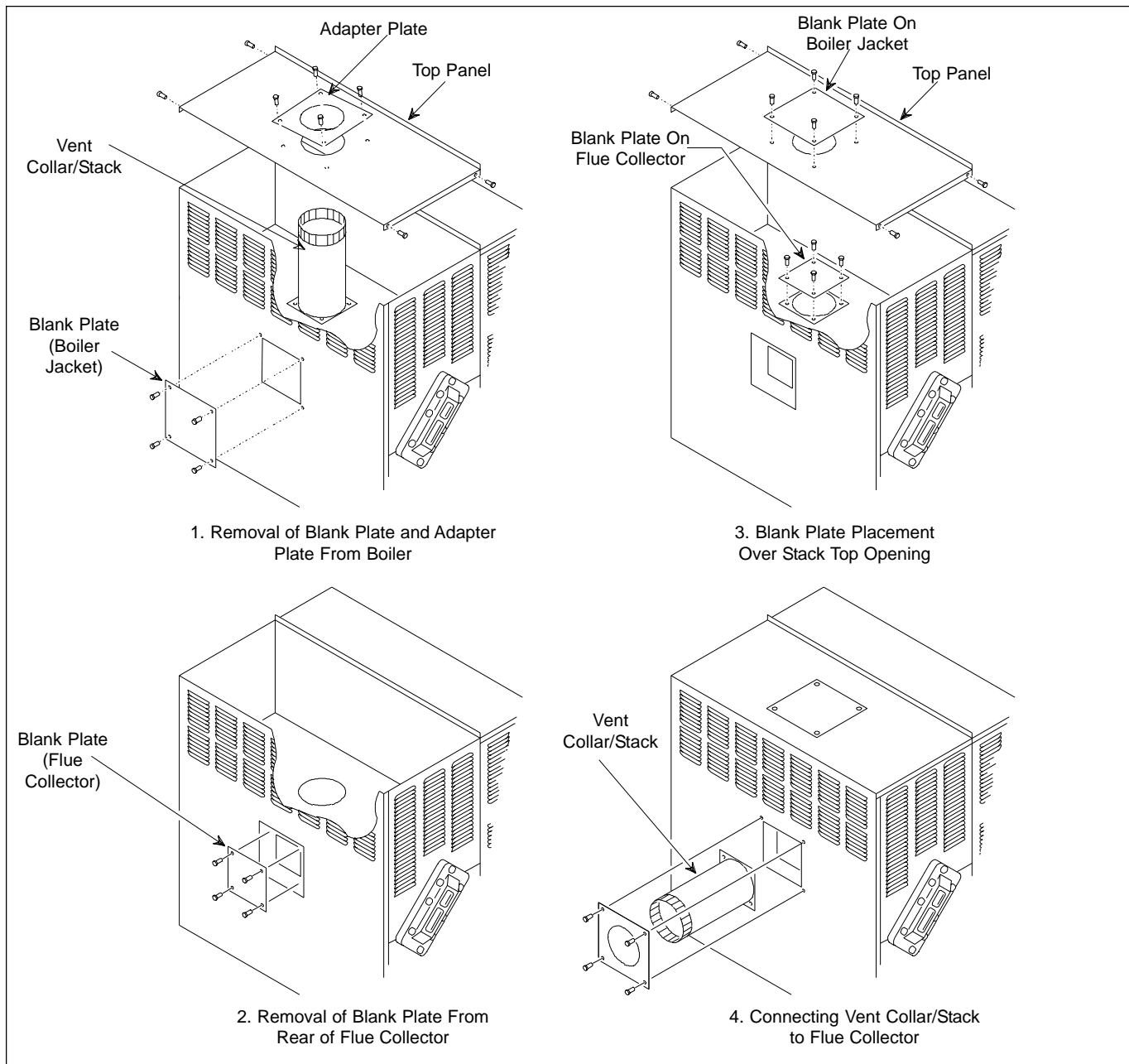

Figure 9. Top-To-Rear Vent Collar.

The Mighty Max HH boiler is certified as a true direct vent unit when installed according to the instructions for horizontal venting and ducted combustion air. This can be done even if the runs are vertical.

2K. Top-to-Rear Vent Collar Conversion

The Mighty Max HH boiler is shipped with the vent collar on top of the heater. Follow this procedure to convert it for rear connection (see Figure 9).

1. Remove the adapter plate from the top panel.
2. On the boiler jacket, remove the top panel and ease its lip from under the edge of the bonnet to gain access to the flue collector.
3. Remove the vent collar/stack from the flue collector. Do not damage the vent collar/stack during removal.
4. Remove the blank plate from the rear of the jacket.
5. Remove the blank plate from the rear section of the flue collector. Be careful not to lose the insulation attached to the plate.
6. Apply high temperature sealant and install the blank plate (previously removed from the rear section of the flue collector) on top of the flue collector.
7. Install the blank plate (previously removed from the rear of the boiler jacket) over the stack opening on the top panel of the boiler.

8. Apply high temperature sealant (see Table 6) to vent collar/stack and install on the rear of the flue collector.

| Term | Description |
|---------------|-------------------------------------------------------------------------------------------------------------------------------|
| Pipe | Type 304, Type 316, or 29-4C stainless steel, 24 gauge minimum |
| Joint Sealing | 3M Type 433 sealing tape with 400°F (204°C) rating or high temperature silicone sealer with 500°F (260°C) rating, Dow No. 736 |
| Insulation | R5 minimum with protective cover |

Table 6. Required Horizontal Venting Material.

9. Slip the adapter plate over the vent collar/stack and install it onto the rear boiler jacket (see Figure 9).

2L. Venting

Venting must be in accordance with these instructions and applicable requirements of the latest edition of ANSI Z223.1/NFPA 54. In Canada, installation must be in accordance with the latest edition of CAN/CGA B149.1 or .2, and applicable local codes.

2L-1. Vertical Venting - Category I

The Mighty Max boiler has a fan-assisted combustion system, so vertical vents must be installed in accordance with the special code requirements for Category I - Fan-Assisted Appliances. These requirements can be found in the latest edition of ANSI Z223.1/NFPA 54, Appendix G, Table 1, and in Canada, CAN/CGA B149.1 or .2, Amendment No. 1. These codes permit installation as a single appliance or in combination with other Category I appliances.

However, there are very important requirements for minimum and maximum vent diameter and length. Make sure vertically-vented installations comply with these codes.

NOTE: If a vent cannot be installed in accordance with the requirements of these codes, it must be installed as a horizontal vent, even if it is mainly vertical.

2L-2. Vertical Venting - Non-Category I

When venting does not meet the code requirements for Category I - Fan-Assisted Vertical Vents, it can develop positive pressure. Such venting must be installed in accordance with this section or Section 2L-3.

The following requirements must be used for Non-Category I venting:

1. Laars specified vent pipe material (Table 6) and sizes (Table 7).
2. Pipe insulation and sealing tape.
3. Routing vent pipe through spaces which, except for the terminal, remain above 60°F (16°C) during heater operation.

2L-3. Horizontal Venting - Non-Category I

When venting is horizontal, or cannot meet the code requirements for Category I - Fan-Assisted Vertical Vents, it can develop positive pressure and must be installed in accordance with this section.

The following requirements must be used for Horizontal Venting - Non-Category I:

1. Laars specified vent pipe material (Table 6) and sizes (Table 7).
2. Laars side wall vent hood.
3. Pipe insulation and sealing tape.
4. Routing vent pipe through spaces which, except for the terminal, remain above 60°F (16°C) during heater operation.

| Heater Size | Pipe Diameter | | Max Pipe Length | | Max No. of Elbows | Side Wall Vent Terminal Part Number | Side Wall Combustion Air Terminal Part Number |
|-------------|---------------|-----|-----------------|----|-------------------|-------------------------------------|-----------------------------------------------|
| | in. | mm | ft. | m | | | |
| 320M | 6 | 152 | 50 | 15 | 5 | D2004500 | 20260701 |
| 400M | 7 | 178 | 50 | 15 | 5 | D2004600 | 20260702 |
| 520M | 8 | 203 | 50 | 15 | 5 | D2004700 | 20260703 |
| 625M | 8 | 203 | 50 | 15 | 5 | D2004700 | 20260704 |
| 775M | 9 | 229 | 50 | 15 | 5 | D2004800 | 20260705 |
| 1000M | 10 | 254 | 50 | 15 | 5 | D2006200 | 20526906 |

IMPORTANT: Maximum pipe length allowed is 50 feet (15m), regardless of the number of elbows. Maximum number of elbows allowed is 5. Vent pipe minimum clearance from combustible surfaces is 6 inches (152mm).

Table 7. Vent Piping Specifications (Combustion Air Exhaust).

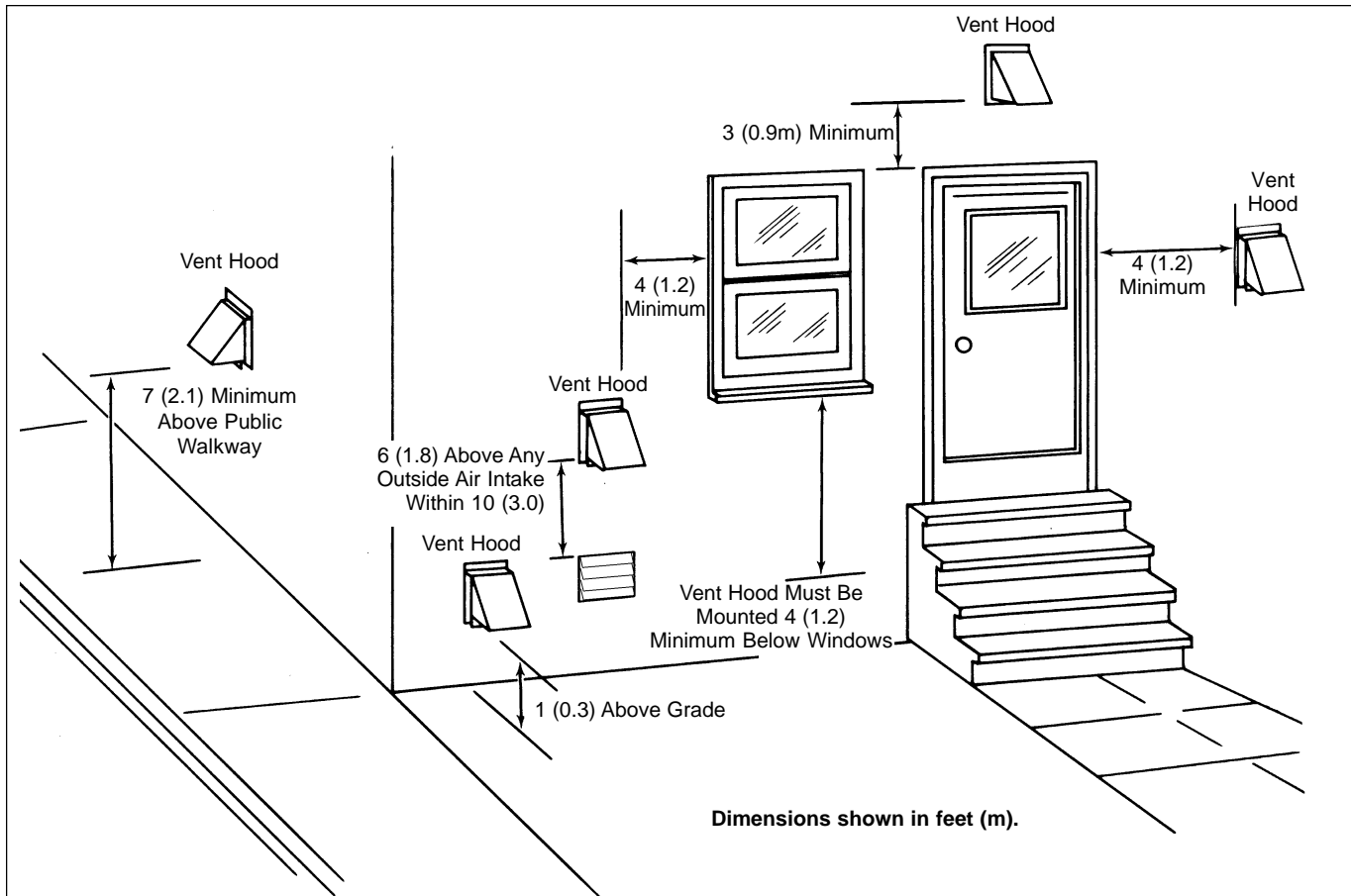

Figure 10. Building Exterior.

2L-4. Side Wall Vent Terminal

The side wall vent hood must be used when the heater is vented through a side wall. It provides a means of installing vent piping through the building wall, and must be located in accordance with ANSI Z223.1/NFPA 54 and applicable local codes. In Canada the installation must be in accordance with CAN/CGA B149.1 or .2 and local applicable codes (see Figure 10). Consider the following when installing the terminal:

1. Locate the vent terminal so that it will not be damaged by pedestrians and other traffic, and so the discharge is not objectionable. The National Fuel Gas Code requires a through-wall vent terminal be at least 7 feet (2.1m) above grade if located at a public walkway.
2. Locate the vent terminal so that vent gases cannot be drawn into air conditioning system inlets. The National Fuel Gas Code requires that it be at least 6 feet (1.8m) above any such inlet that is within 10 feet (3.0m).
3. Locate the vent terminal so that vent gases cannot enter the building through doors, windows, gravity inlets or other openings. The National Fuel Gas Code requires that it be located at least 4 feet (1.2m) below, 4 feet

(1.2m) horizontally from, or 3 feet (0.9m) above such openings.

4. Locate the vent terminal so that it cannot be blocked by snow. The National Fuel Gas code requires that it be at least 12 inches (305mm) above grade, but the installer may determine it should be higher depending on local conditions.
5. Locate the terminal so the vent exhaust does not settle on building surfaces and other nearby objects. Vent products may damage such surfaces or objects. But the actual construction of the vent terminal and the flow of vent products must not be altered.
6. Locate the terminal at least 6 feet (1.8m) horizontally from any gas or electric metering, regulating, or relief equipment, or building opening.

2M. Air for Combustion and Ventilation

The boiler requires air for combustion and the space around the boiler requires ventilation. Combustion air can be provided by standard practices as specified in the installation codes (ANSI Z223.1/NFPA 54, in Canada, CAN/CGA B149.1 or .2 and local applicable codes), or ducted directly to the boiler. Ventilation air must be provided in either case.

2M-1. Air From Room

Standard requirements for providing air for combustion and ventilation are provided by ANSI Z223.1/NFPA 54 and in Canada by CAN/CGA B149.1 or .2. These codes require passages be provided for air flow into the space where the boiler is installed. The size of these passages is based on the firing rate of the boiler and the path of air flow into the space. In general, installations which take air from inside the building require larger passages than those which take air directly through an outside wall.

Failure to provide adequate combustion and ventilation air can cause the boiler, and other appliances occupying the same space, to operate with dangerous and inefficient combustion, and can cause overheating of the space. Be sure to provide air passages in accordance with ANSI Z223.1/NFPA 54, in Canada, CAN/CGA B149.1 or .2 and local applicable codes, and do not permit any other condition, such as an exhaust blower, to affect the air supply for combustion and ventilation.

2M-2. Ducted Combustion Air

Combustion air can be brought directly to the boiler through a duct of suitable size and length (see Table 7). Consult Laars about installations not covered by Table 7.

Combustion air must be taken from out-of-doors by means of the Laars side wall terminal. Locate the terminal within 10 feet (3.0m) of the boiler vent exhaust terminal, but no closer than 3 feet (0.9m) (centerline distance).

Do not locate the air inlet terminal near a source of corrosive chemical fumes (e.g., cleaning fluid, chlorine compounds, etc.). Locate it so that it will not be subject to damage by accident or vandalism. It must be at least 7 feet (2.1m) above a public walkway.

Use single-wall galvanized pipe for the combustion air duct. Route the duct to the heater as directly as possible. Seal all joints with tape. Provide adequate hangers. The heater must not support the weight of the combustion air duct.

When combustion air is ducted to the boiler, other provisions must be made for boiler room ventilation. HH boilers lose less than 1 percent of their input rating to the room, but other heat sources may be present. Provide enough ventilation air to meet comfort specifications. Make sure the ventilation air is not directed at the boiler, water piping or other equipment which could be damaged by freezing.

2M-3. Conversion for Ducted Combustion Air

The conversion to ducted combustion air requires the parts listed in Table 8. Follow these procedures to convert the heater (see Figure 11):

| Boiler Size | Assembly Number |
|-------------|-----------------|
| 320 | 20258101 |
| 400 | 20258102 |
| 520 | 20258103 |
| 625 | 20258104 |
| 775 | 20258105 |
| 1000 | 20258106 |

Table 8. Combustion Air Assembly.

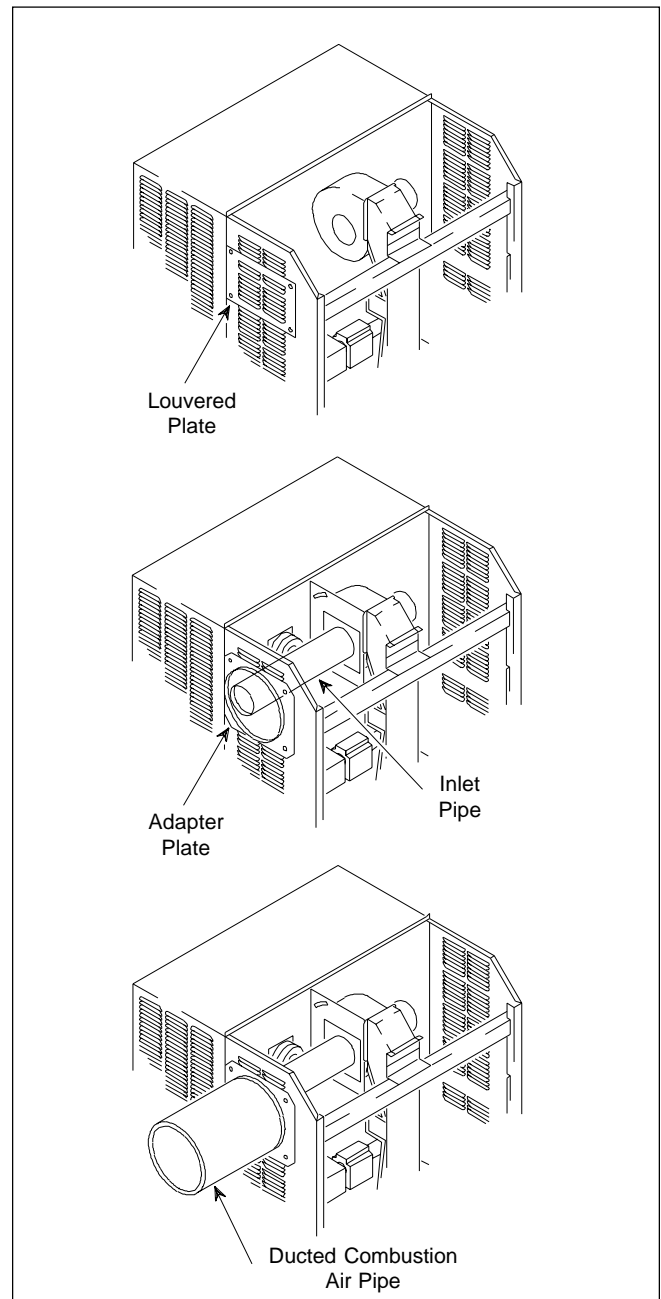

Figure 11. Ducted Combustion Air Conversion.

1. Remove the louvered plate from the left side of the boiler.
2. Remove the adapter plate from the shipping container.
3. Install the blower motor housing collar in gasket.
4. Slip one end of the inlet pipe over the collar on the adapter plate.
5. Slide the inlet pipe and adapter plate into the boiler opening until the pipe is aligned with the blower motor.
6. Slip the end of the inlet pipe over the blower motor housing collar.
7. Secure the adapter plate to the side of the boiler with the 4 screws.

2M-4. Combustion Air Piping

Run piping of the appropriate size between the air intake terminal and the boiler (see Table 7). Table 9 lists the materials for piping the boiler.

| Term | Description |
|---------------|------------------------------------------------------------------------------------------------------------------------------------------------------------------------|
| Pipe | Single-wall galvanized steel pipe, 24 gauge minimum. |
| Joint Sealing | Permanent duct tape or aluminum tape |
| Insulation | Not required, but recommend R5 insulation for cold installations (consult American Society of Heating, Refrigerating, and Air Conditioning Engineers (ASHRAE) handbook |

Table 9. Required Combustion Air Piping Material.

2N. Electrical Wiring

⚠ WARNING

Electrically ground the heater in accordance with the latest edition of ANSI/NFPA 70. In Canada, use CSA C22.1. Do not rely on the gas or water piping to ground the metal parts of the heater. Often, plastic pipe or dielectric unions isolate the boiler electrically. Service and maintenance personnel who work on or around the boiler may be standing on wet floors and could be electrocuted by an ungrounded boiler.

1. Check boiler wiring and pump for correct voltage, frequency, and phase.
2. Wire the boiler and pump exactly as shown in the wiring diagram supplied with the boiler (see Figure 12).

3. Electrically interlock the pump and boiler so the boiler cannot come on unless the pump is running.
4. Connect all field-installed devices (relays, timers, temperature devices, etc.) to the boiler wiring at points labeled “Field Interlock” (see Figure 12).

**SECTION 3.
Operation**

⚠ WARNING

Do not use this appliance if any part has been under water. Immediately call a qualified service technician to replace the appliance.

3A. Start Up Requirements

Lighting: Safe lighting and other performance criteria were met with the gas manifold and control assembly provided on the boiler when it underwent tests specified in ANSI Z21.13 Standard.

Before placing the boiler in operation, check the automatic safety shutoff devices. Once the boiler is connected to the gas piping and after all of the requirements in Section 2 have been met, follow this procedure:

1. Before beginning the tests, make sure the main manual gas valve, and any other boiler firing valves, are in the OFF position.

NOTE: The gas valve is turned off as follows:

- Size 775/1000 Valve is OFF when handle is at right angle to gas pipe.
- Sizes 520/625 Turn clockwise to OFF and
- Sizes 320/400 Press in gas control knob slightly and turn clockwise to OFF. Knob cannot be turned unless it is pushed in slightly. Do not force it.

2. Make sure the power switch on the boiler is in the ON position. Reset all safety devices (high limit, pressure switch, Low-Water-Cutoff, etc.).
3. Normal Operating Sequence
When the circulation pump is running, the boiler will turn itself on and off in response to the water temperature. When the water cools below the set temperature, the following sequence occurs:

- a. The aquastat powers the ignition control.
- b. The ignition control turns on the combustion fan. After about a 15 second

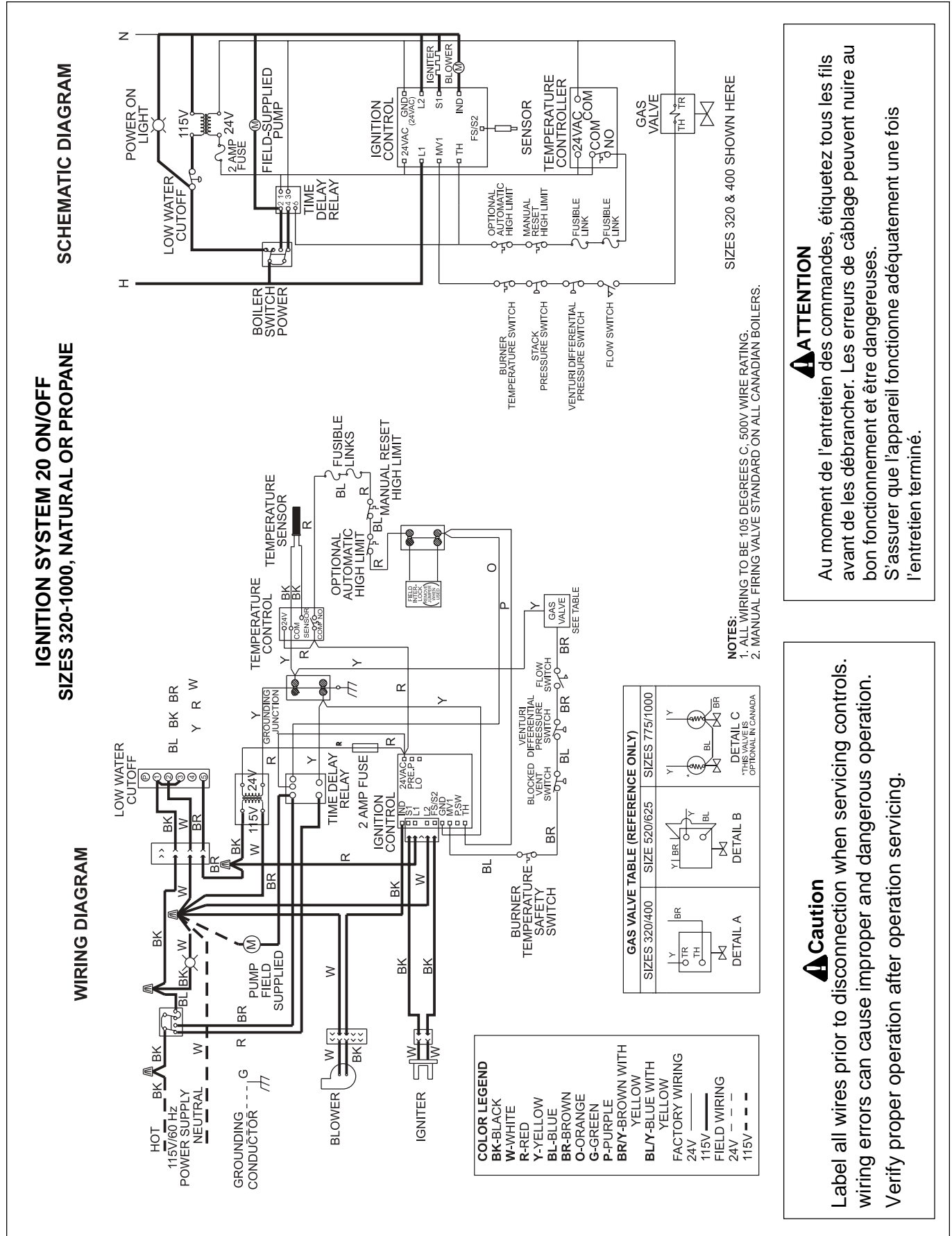

Figure 12. Wiring Diagram.

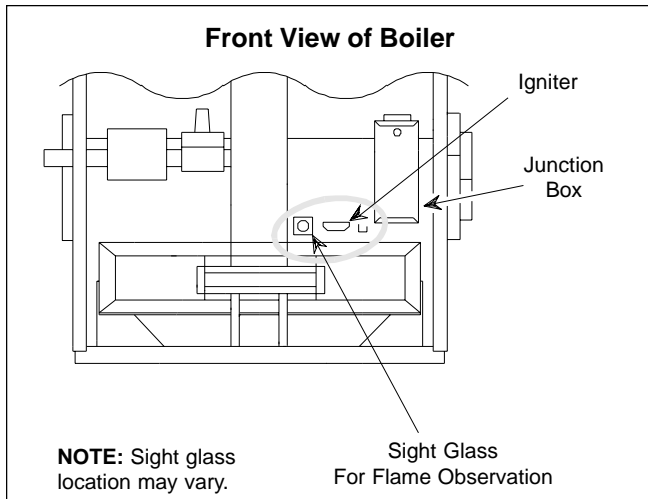

Figure 13. Periodic Flame Observation.

pre-ignition purge, while the fan clears the combustion chamber, the igniter is turned on. The igniter takes about 25 seconds to heat up. You can see a glow through the view port (see Figure 13).

NOTE: The manual gas valve must be ON for the burner to ignite. This valve is turned ON as follows:

- Size 775/1000 Valve is ON when handle is parallel to as pipe.
 - Sizes 320/400 Turn counterclockwise 520/625 to ON.
- c. When the igniter is hot, the ignition control turns on the gas valve and the burner ignites. You can see the burner flame through the view port (see Figure 13).
 - d. The boiler operates until the aquastat senses that the water is hot enough, and the burner shuts off. The combustion fan runs for about one minute to blow all combustion products out of the boiler.

If the igniter fails to ignite the burner in step 3 (for example, if there is air in the gas line), the ignition control shuts off the gas valve after a few seconds of operation. The purge and ignition sequence is automatically repeated. If there is no ignition in three tries, the ignition control “locks out” until the problem is corrected. Contact a qualified service technician.

3B. Hi-Limit Checkout

After running the boiler for a long enough period to bring the water temperature within the range of the hi-limit, slowly back off the high limit setting until the boiler shuts off. The main burners should re-ignite when the hi-limit is turned back up to its original setting and the hi-limit is reset.

3C. Venturi and Gas Pressure Regulator System

3C-1. Overall Operation

The gas control system of the Mighty Max boiler is similar to that of a carburetor of a gasoline engine: a venturi pulls the gas into the combustion air stream (see Figure 14). In this system, changes in combustion air flow automatically change the gas flow.

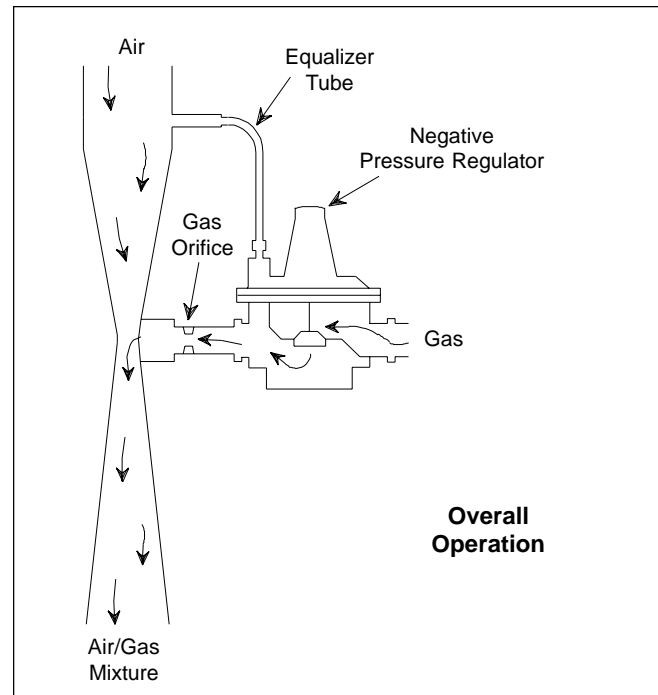

Figure 14. Typical Venturi System.

The flow of air through the venturi creates a pressure difference. At the narrowest point of the venturi, the throat, high velocity creates a low pressure condition which pulls gas in through an orifice.

For a correct gas/air ratio, the gas pressure must be the same as the air pressure, but with a slight negative offset. A special gas regulator (called a “negative pressure regulator”) which has an equalizer tube connected to the venturi inlet, maintains the required gas pressure.

When the system is operating, a combustion fan forces air into the venturi, creating pressure at the inlet. The gas regulator sets gas pressure, and gas is pulled through the orifice. The sizes of the venturi throat and gas orifice are factory set to provide the correct air/gas ratio.

3C-2. Venturi Adjustment

The field checkout involves measuring gas and venturi pressures, and observing the flame through the sight glass. If necessary, the gas input rate can be measured by timing the gas meter.

Use a single, inclined manometer or digital manometer with a 4.0 inch water column range. Install shutoff valves at the gas orifice (regulator outlet) tap (red), at the venturi inlet tap (blue) and at the venturi throat tap (yellow). After installing the shutoff valves, be certain they are closed.

1. With the heater off, connect the positive side of the manometer to the shutoff valve on the venturi inlet tap (blue). Open the shutoff valve.
2. Loosen the nut on the blower damper to allow for adjustment. Turn the boiler on so that the blower is running and the boiler is not firing. In this unfired condition, adjust the damper until the venturi inlet pressure (blue tap) is 1.2 inches water column.
3. Approximately 40 seconds after the blower starts the gas valves will open. The boiler is now firing. If the heater is not running, check all manual gas valves and heater safety devices. Ensure proper gas supply pressures according to the table in Section 2.
4. Now that the boiler is firing, use the blower damper to readjust the venturi inlet pressure according to the installation's altitude in Table 10 (+1.6" w.c. at sea level).

| Elevation Ft. | Venturi Inlet Pressure (Blue Tap) "WC H ₂ O" | Gas Pressure Offset "WC H ₂ O" | Throat Differential Pressure "WC H ₂ O" |
|---------------|---------------------------------------------------------|-------------------------------------------|----------------------------------------------------|
| SEA LEVEL | +1.6 | +0.4 | +2.6 |
| 1000 | +1.5 | +0.4 | +2.5 |
| 2000 | +1.5 | +0.4 | +2.4 |
| 3000 | +1.4 | +0.4 | +2.3 |
| 4000 | +1.4 | +0.3 | +2.2 |
| 5000 | +1.3 | +0.3 | +2.2 |
| 6000 | +1.3 | +0.3 | +2.1 |
| 7000 | +1.2 | +0.3 | +2.0 |
| 8000 | +1.2 | +0.3 | +1.9 |
| 9000 | +1.1 | +0.3 | +1.9 |
| 10000 | +1.1 | +0.3 | +1.8 |

Table 10. Venturi Pressure Settings.

5. Leaving the positive side of the manometer connected to the venturi inlet tap (blue), connect the negative side of the manometer to the shutoff valve on the gas orifice tap (red). Open the shutoff valve to take a pressure reading. This reading is called the gas pressure offset. Using the regulator only, adjust the gas pressure offset according to the installation's altitude in Table 5 (+0.4" w.c. at sea level). **REPLACE THE REGULATOR CAP BEFORE TAKING GAS PRESSURE READINGS.** Turn the regulator screw clockwise to decrease the gas pressure offset, turn the regulator screw counter-clockwise to increase the offset.

6. Using the toggle switch, turn the heater off. Turn the heater back on and check the gas pressure offset after the heater has fired. If the gas offset pressure is not according to Table 10, adjust the regulator as needed.
7. While the heater is still running, close the shutoff valve on the gas orifice tap (red), then remove the manometer hose from the shutoff valve. Connect the negative side of the manometer to the shutoff valve on the venturi throat tap (yellow). This reading is called the venturi throat differential pressure and should appear according to altitude in Table 10 (+2.6" w.c. at sea level). If it does not appear according to Table 10, contact a qualified service technician.

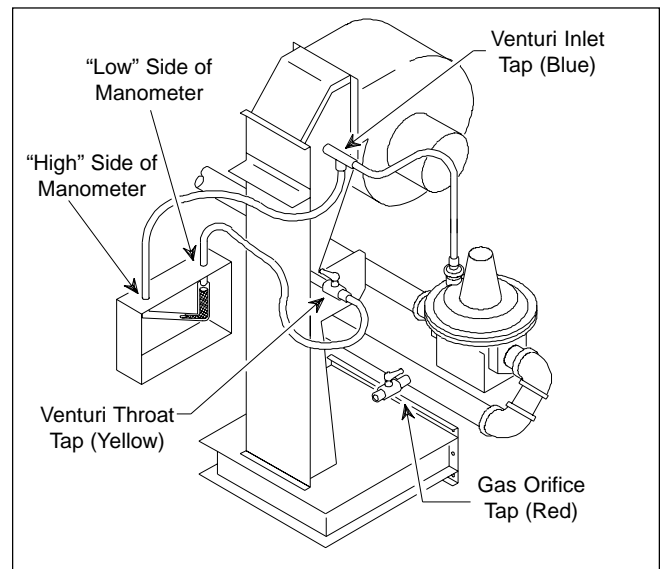

Figure 15. Measurement of Venturi Throat Pressure Differential.

After setting all pressures, turn the heater off and replace each shutoff valve with the factory installed threaded plugs. The venturi has now been adjusted for proper operation.

3D. To Start Up System

(See Section 3A for Startup Requirements)

1. Be certain the system pump is running.
2. Set the thermostat or aquastat to its lowest setting.
3. Turn off electric power to the appliance.
4. Remove the control access panel.
5. Turn off the manual gas valve.
6. Wait five (5) minutes to clear out any gas, then smell for gas, including near the floor. Be sure to smell next to the floor because some gas is heavier than air and will settle on the floor.

Caution

This appliance is equipped with an ignition device which automatically lights the burner. Do not try to light the burner by hand.

WHAT TO DO IF YOU SMELL GAS

- Do not try to light any appliance.
- Do not touch any electric switch; do not use any phone in your building.
- Immediately call your gas supplier from a neighbor's phone. Follow the gas supplier's instructions.

If you don't smell gas, go to the next step.

7. Turn on manual gas valves.
8. Rest all safety devices (manual resets on high limit, low water cutoff, etc.).
9. Replace control access panel.
10. Turn on all electric power to the boiler.
11. Set thermostat to desired setting.
12. If the boiler will not operate, follow the instructions to turn off gas to boiler and call your service technician or gas supplier.
 - a. Turn off main electrical switch.
 - b. Close all manual gas valves.

3D-1. Setting Temperature Controls

The temperature control differential is factory set at 15°F. This setting can be adjusted from 1 to 30°F to suit your application. Adjustment is made by taking the cover off the temperature controller and turning the potentiometer marked "DIFF", which is located just below and to the left of the controller's setpoint dial.

To set the temperature and high-limit controls:

- a. Set the temperature controller at the system design temperature.
- b. For boilers with the temperature controller bulb at the boiler inlet, set the high-limit 40°F to 50°F above temperature controller setting.
- c. For boilers with the temperature controller bulb at the boiler outlet, set the high-limit 15°F to 25°F above temperature controller setting.

3E. To Shut Down System

To shut down the boiler, turn off all manual gas valves and electrical disconnect switch.

NOTE: There is a filter which needs to be cleaned prior to setting pressures. See Section 4D-2 "Filter Service" before proceeding.

3F. Venturi Combustion Flow System

Verifying proper operation of the combustion flow system has two aspects - air flow and gas flow. Air flow is checked by measuring pressures at service

taps on the venturi. Gas flow is checked by evaluating venturi pressures and the regulator offset pressure.

In a venturi flow system the difference between various pressures is far more important than their "gauge" value relative to the room. The gas pressure offset and the gas orifice pressure differential are especially important concepts. The following section describes this setup procedure.

3F-1. Pressure Measurement Ports

Air flow enters the venturi through the filter box and blower assembly. It is pushed through a converging section and into the throat, where pressure is reduced substantially. Gas flow is pulled into the throat through an orifice. The orifice is located between the throat and the regulator. Air and gas are combined in the throat and mix thoroughly as they proceed through the venturi tailpipe to the burner.

Service taps are provided at three places. One is located on the chamber with the gas connection, this tap is called the gas plenum tap. The other is located above the gas plenum tap, this port is called the venturi inlet tap. The third tap, gas orifice tap, is located on the red orifice holder directly before the gas connects to the venturi. These taps have service plugs in them. Do not remove any of the plastic fittings or plastic tubing. To evaluate system operation requires accurate measurement at these taps. An inclined manometer with a zero to 6 inches water column range is ideal. Other instruments may be used, but the "positive/negative" nature of the readings must be well understood. Gas pressure offset measurements are at very low levels (0.4" WC), the instrumentation must be capable of determining it accurately.

3F-2. Venturi Adjustment

Note that an equalizer tube is connected from a port on the side of the venturi inlet to the port of the regulator. This is a very important component which allows the regulator to track air pressure even when abnormal conditions occur, such as blockage of the combustion air. Before firing, confirm that this tube and the venturi pressure switch tubes are in place and firmly connected.

The field checkout involves measuring gas and venturi pressures, and observing the flame through the sight glass. If necessary, the gas input rate can be measured by timing the gas meter.

Install shutoff valves at the gas orifice (regulator outlet) tap (red), at the venturi inlet tap and at the gas plenum tap. Do not remove any of the plastic fittings or plastic tubing. After installing the shutoff valves, be certain they are closed.

a. Unfired Venturi Differential Pressure

NOTE: Turn off the main manual gas valve.

The difference in pressure between the venturi inlet tap and the gas plenum tap (see Figure 16). This measurement is taken by connecting the positive side of the manometer to the venturi inlet tap and connecting the negative side of the manometer to the gas plenum tap. This measurement is taken with the boiler not firing. It is a temporary setting used to start the boiler and check for air flow problems.

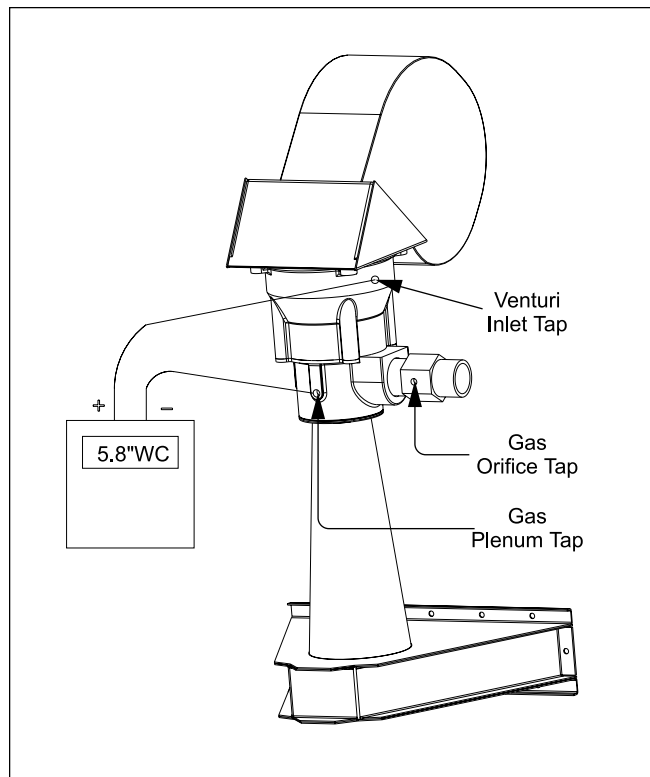

Figure 16. Unfired Venturi Differential Pressure.

b. Gas Offset Pressure

The difference in pressure between the venturi inlet tap and the outlet of the gas regulator (see Figure 17). This measurement is taken by connecting the positive side of the manometer to the venturi inlet tap and connecting the negative side of the manometer to the gas orifice tap. This measurement is an indication of the gas to air ratio and must be performed while the unit is firing.

c. Gas Orifice Differential Pressure

This measurement is the pressure drop across the gas orifice. This measurement is taken by connecting the positive side of the manometer to the gas orifice tap and the negative side of the manometer to the gas plenum tap (see Figure 18). This measurement in conjunction with the gas orifice size is an indication of the gas firing rate and must be performed while the unit is firing.

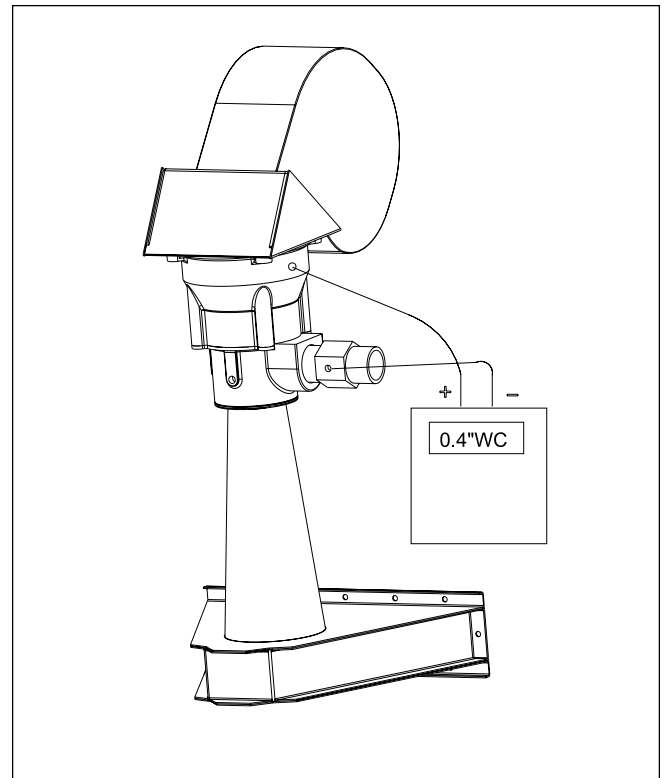

Figure 17. Gas Offset Pressure.

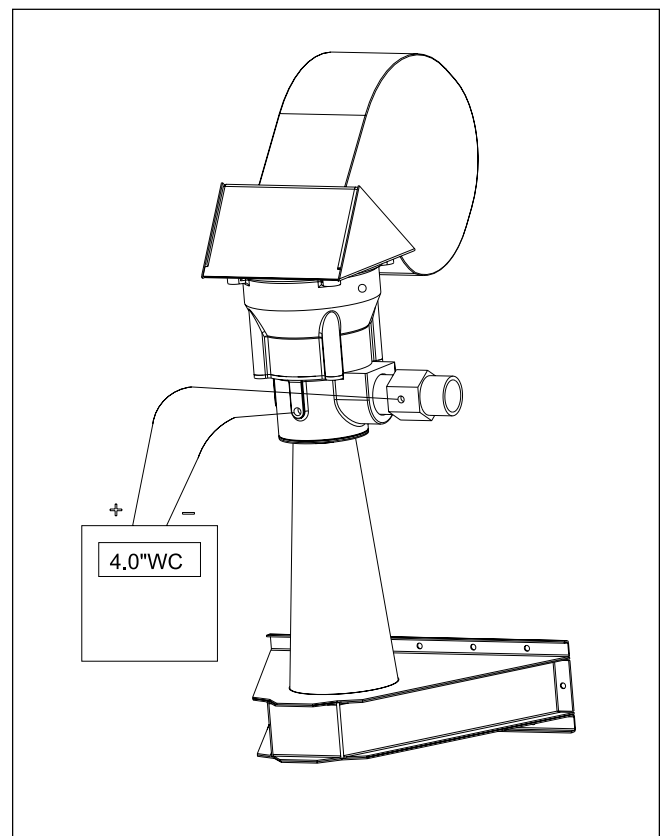

Figure 18. Gas Orifice Differential Pressure.

By setting the gas offset pressure and gas orifice differential pressure according to Table 11, the correct input rate and gas to air ratio is achieved.

| ELEVATION, FT | GAS OFFSET PRESSURE inch W.C. | GAS ORIFICE DIFFERENTIAL PRESSURE inch W.C. | UNFIRED VENTURI DIFFERENTIAL inch W.C. |
|------------------|----------------------------------------|------------------------------------------------------|-------------------------------------------------|
| SEA LEVEL | +0.4 | +4.0 | +5.8 |
| 2000 | +0.4 | +3.7 | +5.3 |
| 4000 | +0.4 | +3.4 | +4.9 |
| 6000 | +0.4 | +3.2 | +4.6 |
| 8000 | +0.4 | +2.9 | +4.2 |
| 10000 | +0.4 | +2.7 | +3.9 |

Table 11. Venturi Pressure Settings.

3F-3. Venturi Setup Procedure

- Loosen the nut on the blower shutter to allow for adjustment. Turn the heater on so that the blower is running and the heater is not firing. Measure the *unfired venturi differential pressure*. In this unfired condition, adjust the shutter until the unfired venturi differential pressure is according to Table 1, "Unfired Venturi Differential" ($5.8 \pm .3$ inches wc at sea level). If this pressure range can not be achieved, check for blockage in the combustion air inlet, boiler and venting system. If there is no obvious cause contact a qualified Laars service technician.
- Approximately 40 seconds after the blower starts the gas valves will open. The heater is now firing. If the heater is not running, check all manual gas valves and heater safety devices. Ensure proper gas supply pressures according to Table 4 in Section 2.
- Measure the *gas offset pressure*. Using the regulator only, adjust the gas offset pressure according to the installation's altitude in Table 11 (+0.4 inches wc. at sea level). **REPLACE THE REGULATOR CAP BEFORE TAKING GAS PRESSURE READINGS.** Turn the regulator screw clockwise to decrease the gas offset pressure, turn the regulator screw counterclockwise to increase the offset.
- Using the toggle switch, turn the heater off. Turn the heater back on and check the gas offset pressure while the heater is firing. If the gas offset pressure is not according to Table 11, adjust the regulator as needed.
- Measure the *gas orifice differential pressure*. This pressure must be adjusted according to Table 1 ($4.0 \pm .2$ inches wc at sea level). Use the blower shutter to adjust the gas orifice differential.
- By adjusting the gas orifice differential, the gas offset pressure will change. Therefore you must

repeat steps 3-5 until the gas offset and gas orifice differential pressures are according to Table 11.

- After setting all pressures, turn the heater off and replace each shutoff valve with the factory installed threaded plugs. The venturi has now been adjusted for proper operation.

SECTION 4. Maintenance

4A. General Instructions

- Oil the water circulating pump in accordance with the manufacturer's instructions.
- Oil the blower motor bearings every 6 months.
- If a strainer is used in a pressure reducing valve or in the piping, clean it every 6 months in accordance with the manufacturer's instructions.
- At startup and every 6 months after, look at the main burner flame for proper performance. The burner should not require maintenance in normal operation. If any malfunction indicates that the burner needs service (e.g., a flame that is yellow, or entire burner surface glowing red), call a professional service technician. Flame characteristics may be inspected during the first 30 seconds after ignition. Characteristics of a good flame are:
 - Blue flame color.
 - Dark-colored burner surface with occasional glowing fibers on surface.

NOTE: After 30 seconds of operation the combustion chamber will heat up and prevent reliable flame observation.

- Inspect the venting system for blockage, leakage, and corrosion at least once a year.
- Keep the heater area clear of combustible material, gasoline, and other flammable liquids and vapors.
- Be sure all combustion air and ventilation openings are not blocked.
- After installation and first startup, check the heat exchanger for black carbon soot buildup after the following periods of operation: 24 hours, 7 days, 30 days, 90 days, and once every 6 months thereafter.

4B. Heat Exchanger

Black carbon soot buildup on the external surfaces of the heat exchanger is caused by one or more of the following: incomplete combustion, combustion air problems, venting problems and heater short cycling. As soon as any buildup is seen, correct the cause of the buildup. **Scale can build up on the**

inner surface of the heat exchanger tubes and restrict the water flow. Inspect the heat exchanger in accordance with Section 4B-1.

If the heat exchanger needs cleaning, see Section 4B-2.

4B-1. Inspection of the Heat Exchanger

WARNING

Improper installation or maintenance can cause nausea or asphyxiation from carbon monoxide in flue gases which could result in severe injury, property damage, or death.

4B-1a. External Heat Exchanger Inspection

1. Disconnect electrical supply to the heater.
2. Turn off the gas supply by closing the manual gas valve on the heater.
3. On indoor models, remove the vent pipe, top jacket section, flue collector.
4. On outdoor models, remove outdoor vent terminal, top jacket section, flue collector.
5. After removing the flue collector, inspect the finned copper tubing using a flashlight.
6. If there is a buildup of black carbon soot or other debris on the heat exchanger tubes which may restrict flue gas passage, refer to Section 4B-2a.
7. If there is no buildup of black carbon soot or other debris which may restrict flue gas passage through the heat exchanger, reassemble the heater.

4B-1b. Internal Heat Exchanger Inspection

1. Remove the inlet/outlet header of the heat exchanger.
2. Remove the return cover of the heat exchanger.
3. Inspect the internal surface of the copper tubes for signs of scale buildup and erosion.
4. If build-up exists, clean per 4B-2b.

4B-2. Cleaning the Heat Exchanger

4B-2a. Cleaning the Heat Exchanger - External

NOTE: The heat exchangers are heavy and may require two people to remove to avoid personal injury.

Caution

Black carbon soot buildup on a dirty heat exchanger can be ignited by a random spark or flame. To prevent this from happening, dampen the soot deposits with a wet brush or fine water spray before servicing the heat exchanger.

1. Disconnect the 120 Vac electrical supply to the heater.
2. Turn off the gas supply by closing the manual gas valve on the heater.
3. Disconnect and remove the wires and conduit from the low water cutoff.
4. Remove the top jacket section, venting and the flue collector as mentioned in Section 4B-1 "Inspection of the Heat Exchanger".
5. Isolate the heat exchanger from water supply.
6. Drain the heat exchanger.
7. Disconnect the flange and adapter tee from the heat exchanger inlet and outlet.
8. Remove temperature sensing probes from the inlet/outlet header.
9. Remove the heat exchanger from the heater.
10. Remove the heat baffles from the heat exchanger.
11. Clean the heat exchanger: A light accumulation of soot or corrosion on the outside of the heat exchanger can be easily removed after the heat baffles are removed. Use a wire brush to remove loose soot and scale from the heat exchanger. Do not use water or compressed air for cleaning.

NOTE: While the heat exchanger is out of the heater, inspect the firewall refractory insulation blocks for cracks, wear and breakage. Replace if necessary.

4B-2b. Cleaning the Heat Exchanger - Internal

1. Remove the inlet/outlet header of the heat exchanger.
2. Remove the return cover of the heat exchanger.
3. Clean the internal surface. (Laars offers a tube cleaning kit part no. R00100000.)
4. Reassemble in the reverse order.

4C. Gas and Electric Controls

The gas and electric controls on the heaters are designed for both dependable operation and long life. Safe operation of the heater depends on their proper functioning. A professional service technician should check the following basic items every year, and replace when necessary.

NOTE: the warranty does not cover damage caused by lack of required maintenance or improper operating practices.

1. Water temperature controls.
2. Ignition control system.
3. Automatic electric gas valve(s).
4. Flow sensing safety device (when used).
5. Low water cutoffs, including flushing or float types. (Every six months)

Other maintenance requirements include:

1. Periodic cleaning of filters, when supplied.
2. Lubrication of moving parts (when applicable), with the correct type and amount of lubricant.
3. Periodic examination of the venting system.
4. Periodic cleaning of vent terminal screens, where applicable.
5. Cleaning flue gas passageways.

4D. Filter

4D-1. Filter Function

A filter has been designed into the operation of this Mighty Max boiler. Its function is to filter the combustion air before it is delivered to the burner system. The filter is manufactured out of a polyurethane foam and may be cleaned with a mild soap and water solution. Clean the filter only after the filter has been removed from the filter housing (see Figure 19).

4D-2. Filter Service

(The filter does not need cleaning if this is a first time heater start-up).

1. Turn the heater off using the toggle switch.
2. Remove the door panel and bonnet from the jacket.
3. Remove the screws on the filter housing to expose the filter as shown in Figure 19.

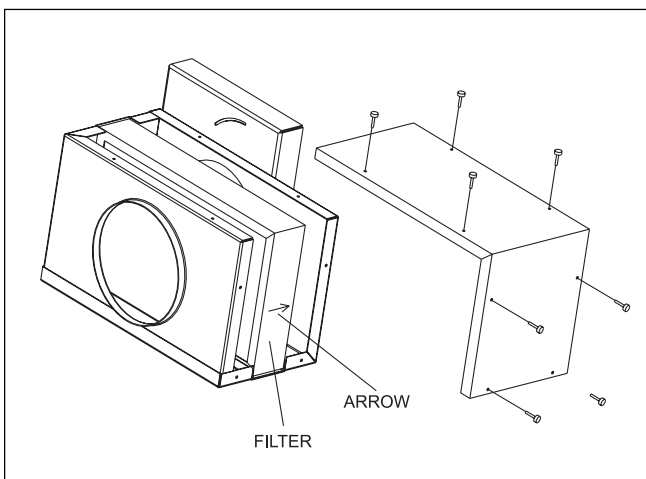

Figure 19. Filter Exposed for Cleaning.

4. Inspect the filter for discoloration due to contamination or any other forms of debris. If contamination or debris exists, wash the filter in a soap/water solution then rinse with water only. It is important that the filter be dry before placing it back in the filter housing.

⚠ Caution

The filter has arrows which indicate the direction of the air flow. Failure to install the filter correctly may cause blower failure and dangerous operation.

The filter must be inspected for contamination one week after start-up. Depending upon the severity of contamination, a suitable cleaning schedule may be developed. The factory recommends cleaning the filter at least once every 30 days. In high contamination areas, such as construction sites, factories, etc., the filter may need to be cleaned daily. Failure to do so could result in lower heat output and potential unsafe operation.

SECTION 5 Troubleshooting

5A. Sequence of Operation

To troubleshoot the heater properly you must first understand the sequence of operation of the heater:

1. Upon a call for heat a 24 Vac signal is sent through fusible links and high limit(s) to the ignition control “TH” terminal.
2. The “IND” terminal of the ignition control is energized for a 15 second pre-ignition purge period during which the combustion blower purges the combustion chamber.
3. After the purge period there is a 20 to 35 second igniter heat up period. The glow of the igniter can be seen through the boiler sight glass.
4. Then there is a seven second trial for ignition. During this time the gas valves are energized and the main burner ignites. The gas valves will remain energized throughout the call for heat as long as the ignition control igniter senses a stable flame.
5. After the call for heat is satisfied the ignition control closes the gas valves and operates the blower for a thirty (30) second post purge cycle. This clears the combustion chamber of combustion products.

The ignition is attempted three times. If ignition is not successful, the control shuts down and “locks out”. It remains in the lockout condition until the boiler is turned off then back on or 120 Vac power to the boiler is interrupted.

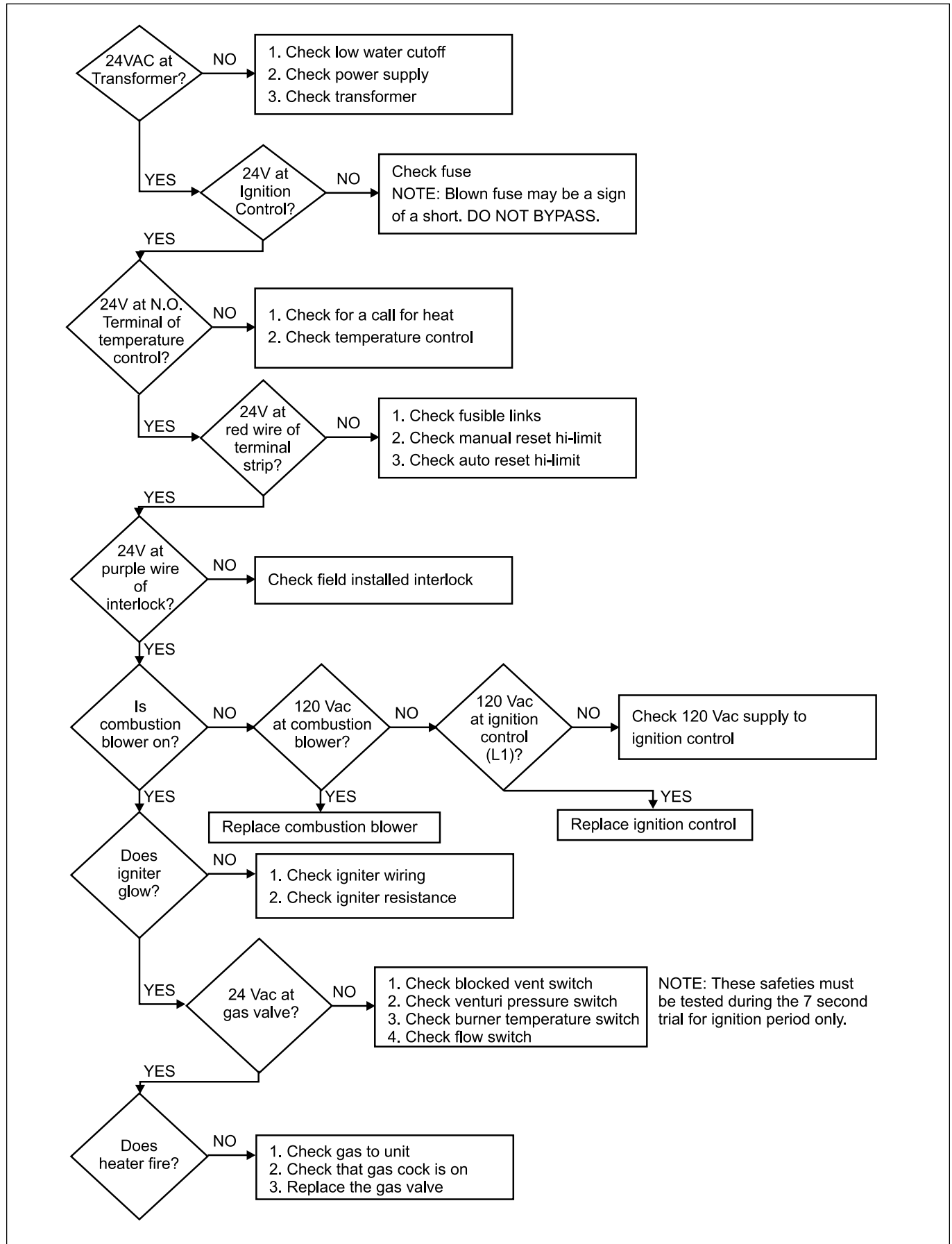

Figure 20. Troubleshooting Chart.

5B. Venturi and Gas Pressure Regulator System

5B-1. Field Checkout

See Section 3B “Venturi and Gas Pressure Regulator System” for proper setup procedure.

5C. Electrical Components

This section describes guidelines for checking the operation of electrical components installed on the boiler. Refer to the wiring diagram for correct connection locations.

5C-1. General Troubleshooting

This section describes guidelines for checking the electrical components of the boiler. Experience has shown that most complaints about boilers failing to fire have nothing to do with the boiler itself. Usually, one of the protective switches in the boiler system has shut down operation.

Any of the following can prevent proper operation. Check these items first:

1. Be sure the boiler has been properly installed (see Section 2).
2. Make sure the pump is not airlocked, clogged or otherwise inoperative.
3. Make sure the gas valve is on and there is sufficient gas pressure in the line. All external gas valves must be open.
4. Verify that the electrical circuit serving the boiler is ON.
5. Make sure the toggle switch on the right side of the boiler is ON.
6. Check the fuse inside the black, twist-lock fuse holder. If it is burned, replace it with a 2-amp fuse (part no. E0084400).
7. With the power off inspect all electrical connections and wiring. Finding a loose connection or charred wire can save a lot of time and money.
8. Make sure the temperature controller is set high enough to call for heat.
9. Make sure none of the manual reset controls, i.e., low water cutoff, high limit, etc., have tripped. Reset any tripped switches.

If the pump is circulating water and the foregoing items check out okay, the trouble may be in the boiler control system.

IMPORTANT: Disconnect power to the boiler before removing or replacing any component or wire connection. If the power is not disconnected, “jumping” the gas valve or accidentally grounding the wire harness or component terminals to the boiler frame or jacket could cause the ignition control fuse to blow.

5C-2. Electrical Troubleshooting

Troubleshooting procedures should only be performed by professional service technicians qualified in heater maintenance.

Some electrical components are wired in parallel, so it is necessary to troubleshoot in the order that they appear on the wiring diagram or the troubleshooting flow chart (see Figure 20).

NOTE: When testing the safeties between “MV1” of the ignition control and the gas valve(s) there is only a seven (7) second trial for ignition period during which there is power to “MV1”.

The following steps should be used when troubleshooting the boiler:

1. Remove the lower front panel (see Figure 21).
2. Turn the manual gas valve on the heater off.
3. If the heater has locked out turn the toggle switch off for 5 seconds then back on to reset the heater.
4. Use the troubleshooting flow chart (see Figure 20) to determine what components and wiring should be tested first.
5. Test each component by checking for 24 Vac or 120 Vac entering and exiting the device. If there is voltage entering the safety device, but none leaving then there is an open circuit and it must be determined why it is open. When testing components between “MV1” of the ignition control and the gas valve install a meter and let the heater cycle through one complete sequence of operation. During the sequence of operation these safeties will only be energized for the seven second trial for ignition.
6. Turn the manual gas valve on the boiler on and fire the boiler.

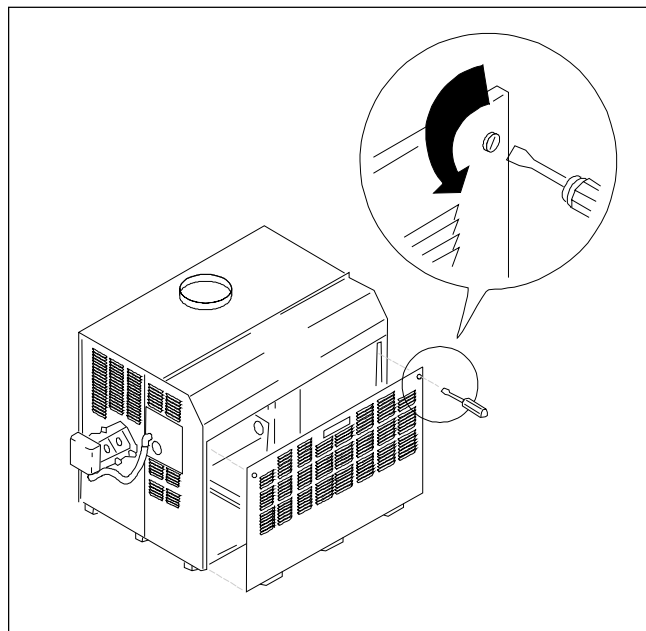

Figure 21. Lower Front Panel Removal.

SECTION 6 Parts List for Mighty Max HH Boiler

6A. General Information

To order or purchase parts for the Laars Mighty Max HH boiler, contact your nearest Laars contractor or distributor. If they cannot supply you with what you need, contact:

Laars Customer Service Department
6000 Condor Drive
Moorpark, California 93021
Telephone (805) 529-2000
(800) 900-9276

or
Laars Customer Service Department
20 Industrial Way
Rochester, New Hampshire 03867
Telephone (603) 335-6300.

In Canada, contact:
Laars Customer Service Department
480 S. Service Road West
Oakville, Ontario, Canada L6K 2H4
Telephone (905) 844-8233.

| Item | Description | Part Number |
|------|-----------------------------------|-------------|
| 1. | Base Assembly | |
| | 320M | 20157801 |
| | 400M | 20157802 |
| | 520M | 20157803 |
| | 625M | 20157804 |
| | 775M | 20157805 |
| | 1000M | 20157806 |
| 2. | Burner and Burner Plenum Weldment | |
| | 320M | 20157901 |
| | 400M | 20157902 |
| | 520M | 20157903 |
| | 625M | 20157904 |
| | 775M | 20157905 |
| | 1000M | 20157906 |
| 3. | Venturi Assembly | |
| | 320M | 20158601 |
| | 400M | 20158602 |
| | 520M | 20158603 |
| | 625M | 20158604 |
| | 775M | 20158605 |
| | 1000M | 20266400 |
| 4. | Combustion Chamber Weldment | |
| | 320M | 20159101 |
| | 400M | 20159102 |
| | 520M | 20159103 |
| | 625M | 20159104 |
| | 775M | 20159105 |
| | 1000M | 20159106 |
| 5. | Gas Train Assembly | |
| | 320M | 20254901 |
| | 400M | 20254902 |

| Item | Description | Part Number |
|------|-------------------------------------------------|--------------------------------------|
| | 520M, 625M | 20260100 (U.S.) 20260101 (Canada) |
| | 775M | 20260200 (U.S.) 20260201 (Canada) |
| | 1000M | 20265600 (U.S.) 20265601 (Canada) |
| | Gas Valve | |
| | 320M, 425M | V2003900 |
| | 520M, 625M | V2003700 |
| | 775M, 1000M | V0046700 |
| | Pressure Regulator | |
| | 520M, 625M | V2003800 |
| | 775M, 1000M | V2003600 |
| | Orifice Holder | |
| | 320M, 400M | P2017500 |
| | 520M, 625M | P2017700 |
| | 775M | P2018500 |
| | 1000M | P2022200 |
| 6. | Motor, Blower | |
| | 320M thru 520M Nat. & Prop. Gas | A2088100 |
| | 625M, 775M Nat. & Prop. Gas | A2087500 |
| | 1000M Nat. & Propane Gas | A2003900 |
| 7. | Electrical Controls | |
| | High limit Control | E0015900 |
| | Toggle Switch | E0109200 |
| | Indicator Light | E0071300 |
| | Fusible Link | E0099403 |
| | Transformer | E0086100 |
| | Fuse Holder | E2000300 |
| | Fuse, 2 Amp | E2043600 |
| | Flow Switch | E0013000 |
| | Burner Temperature Switch | E2076100 |
| | Low Water Cutoff | E2075100 |
| | Pump Time Delay | E2077700 |
| 8. | Sight Glass | F0044800 |
| 9. | Igniter, Hot Surface | W0038001 |
| 10. | Gasket, Igniter Hot Surface | 20409800 |
| 11. | Control, Remote Ignition | E2101300 |
| 12. | Control, Temperature | E2101400 |
| 13. | Display, Temperature | E2101600 |
| 14. | Heat Exchanger Assy., 2 pass, Copper Tubes | |
| | 520M | 20256003 |
| | 625M | 20256004 |
| | 775M | 20256005 |
| | 1000M | 20256006 |
| | Heat Exchanger Assy., 2 pass, Cupronickel tubes | |
| | 520M | 20104603 |
| | 625M | 20104604 |
| | 775M | 20104605 |
| | 1000M | 20104606 |
| 15. | Heat Exchanger Assy., 4 pass, Copper Tubes | |
| | 320M | 20259601 |
| | 400M | 20259602 |
| | Heat Exchanger Assy., 4 pass, Cupronickel tubes | |
| | 320M | 20104701 |
| | 400M | 20104702 |

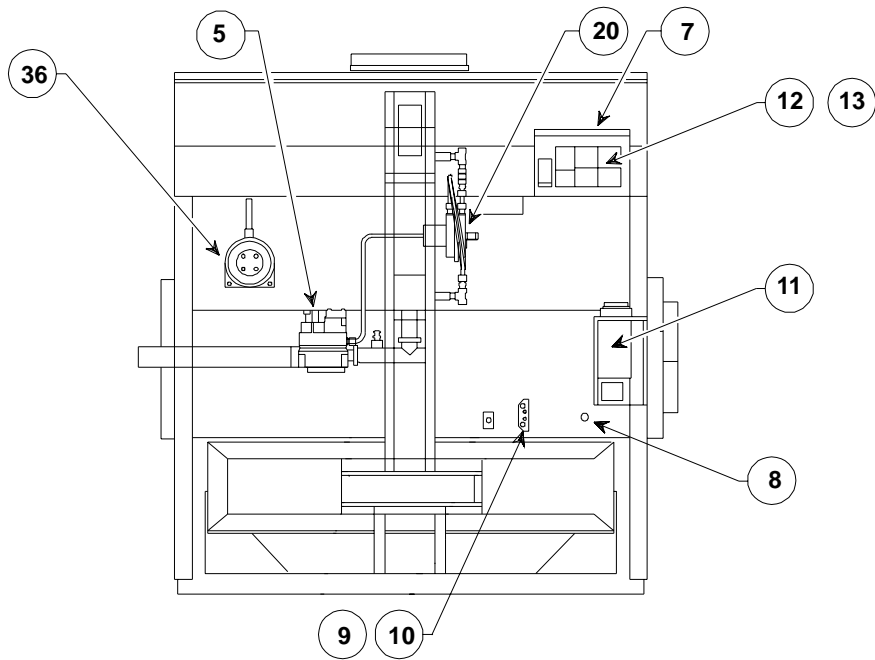

Front View

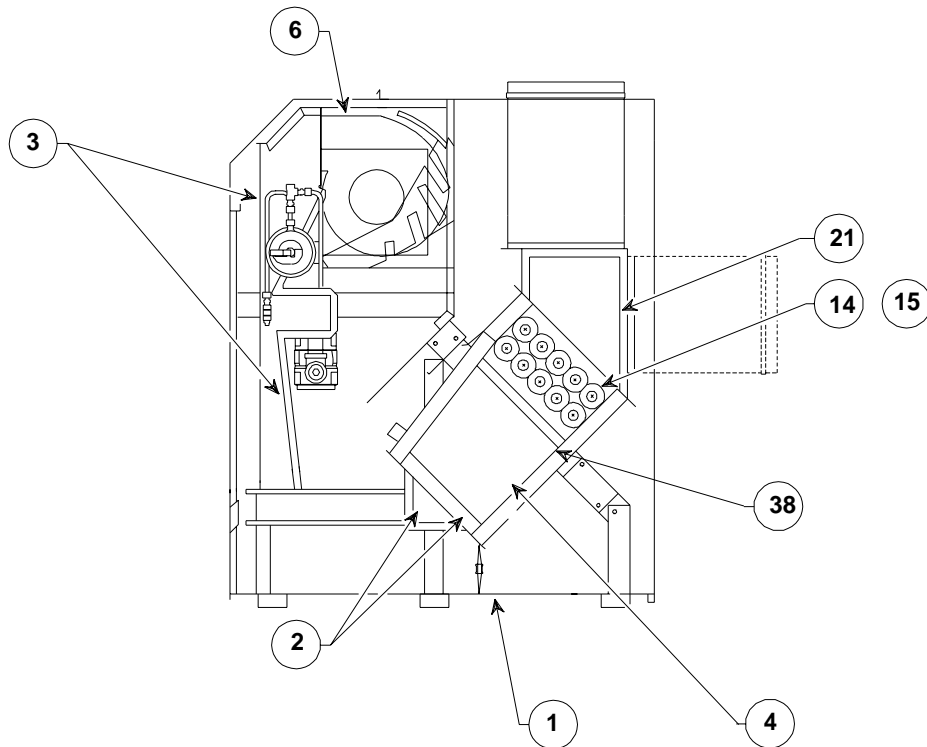

Right Side View

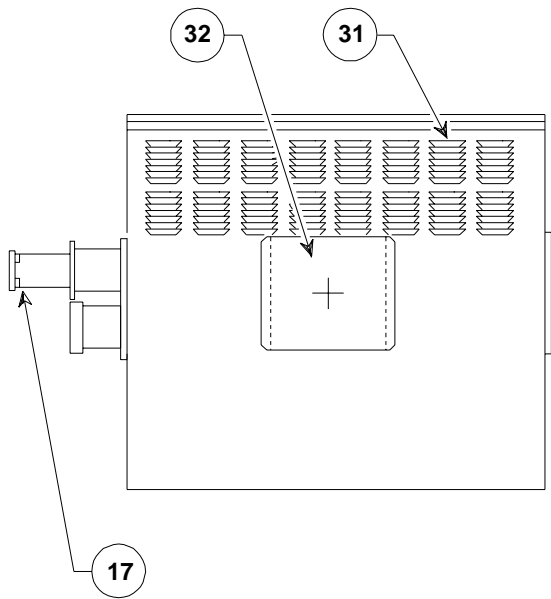

Rear View

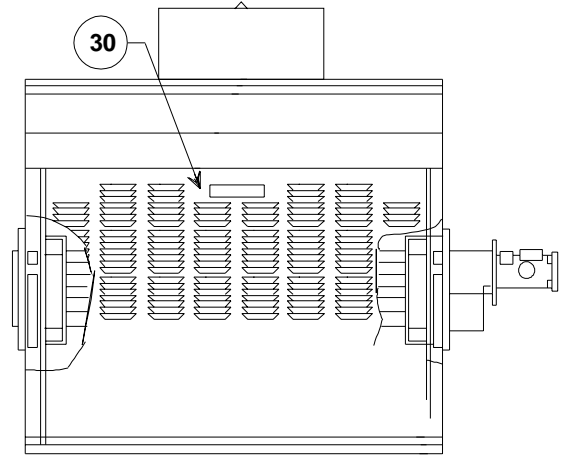

Front View

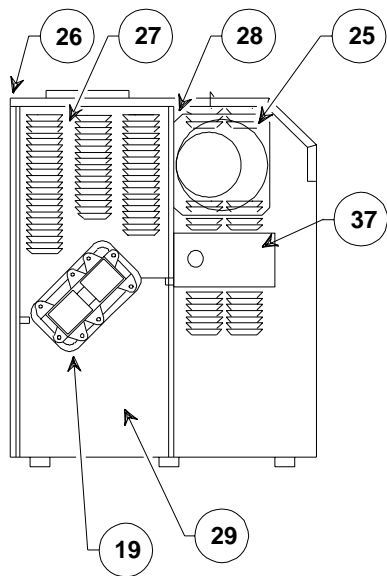

Left Side View

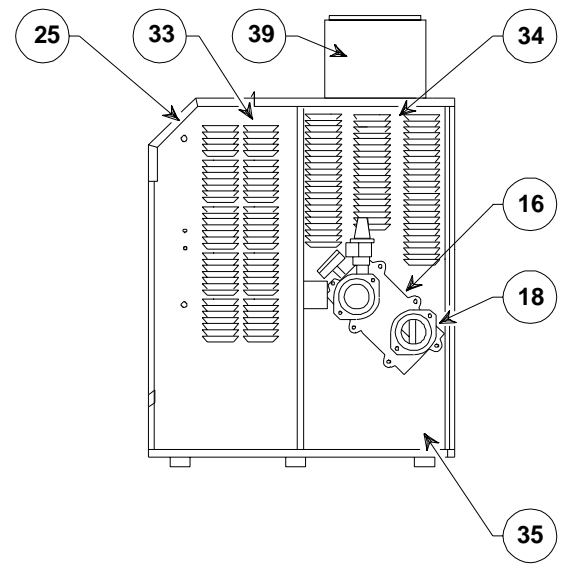
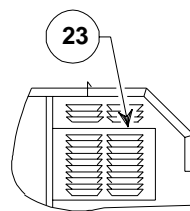

Right Side View

| Item | Description | Part Number |
|------|---------------------------------------------|-------------|
| 16. | Cover, Machined In/Out | 20150200 |
| 17. | Plate, Mach. Adapter | |
| | 320M, 400M | 20150302 |
| | 520M, 625M, 775M | 20150306 |
| | 1000M | 20150307 |
| 18. | Flange, Machined | |
| | 320M, 400M | 20255400 |
| | 520M, 625m, 775M | 20255401 |
| | 1000M | 10391304 |
| 19. | Cover, Machined Rear | 20150100 |
| 20. | Pressure Switch, Differential 320-775 | E0115200 |
| | Pressure Switch, Differential 1000 | E0161400 |
| 21. | Flue Collector Assembly (with gaskets) | |
| | 320M | 20155401 |
| | 400M | 20155402 |
| | 520M | 20155403 |
| | 625M | 20155404 |
| | 775M | 20155405 |
| | 1000M | 20155406 |
| 22. | Jacket Assembly (Not Shown) | |
| | 320M | 20255201 |
| | 400M | 20255202 |
| | 520M | 20255203 |
| | 625M | 20255204 |
| | 775M | 20255205 |
| | 1000M | 20255206 |
| 23. | Covering Plate (side) | 20256500 |
| 24. | Collar, Jacket 320-775 | 20258300 |
| | Collar, Jacket 1000 | 20266300 |
| 25. | Bonnet | |
| | 320M | 20156801 |
| | 400M | 20156802 |
| | 520M | 20156803 |
| | 625M | 20156804 |
| | 775M | 20156805 |
| | 1000M | 20156806 |
| 26. | Panel Top, | |
| | 320M | 20157501 |
| | 400M | 20157502 |
| | 520M | 20157503 |
| | 625M | 20157504 |
| | 775M | 20157505 |
| | 1000M | 20157506 |
| 27. | Panel, Top Side, Left | 20152800 |
| 28. | Panel, Side, Left | 20152700 |
| 29. | Panel, Bottom Side, Left | 20152900 |
| 30. | Panel, Access | |
| | 320M | 20157401 |
| | 400M | 20157402 |
| | 520M | 20157403 |
| | 625M | 20157404 |
| | 775M | 20157405 |
| | 1000M | 20157406 |

| Item | Description | Part Number |
|------|-----------------------------------------------------|-------------|
| 31. | Panel, Back | |
| | 320M | 20157201 |
| | 400M | 20157202 |
| | 520M | 20157203 |
| | 625M | 20157204 |
| | 775M | 20157205 |
| | 1000M | 20157206 |
| 32. | Plate, Blank (back) | |
| | 320M | 20256201 |
| | 400M | 20256202 |
| | 520M, 625M | 20256203 |
| | 775M | 20256204 |
| | 1000M | 20256205 |
| 33. | Panel, Side, Right | 20157100 |
| 34. | Panel, Top Side, Right | 20157000 |
| 35. | Panel, Bottom Side, Right | 20156900 |
| 36. | Blocked Vent Safety Switch | E2103000 |
| 37. | Cover Plate For Gas Conn. | |
| | 320M, 400M | 20262701 |
| | 520M, 625M | 20262702 |
| | 775M, 1000M | 20262703 |
| 38. | Tile Assembly | |
| | 320M | 20255101 |
| | 400M | 20255102 |
| | 520M | 20255103 |
| | 625M | 20255104 |
| | 775M | 20255105 |
| | 1000M | 20255106 |
| 39. | Outdoor Terminal Kit | |
| | 320M | 20254701 |
| | 400M | 20254702 |
| | 520M | 20254703 |
| | 625M | 20254703 |
| | 775M | 20254704 |
| | 1000M | 20254705 |
| 40. | Side Wall Vent Terminal (When Used) (Not Shown) | |
| | 320M | D2004500 |
| | 400M | D2004600 |
| | 520M | D2004700 |
| | 625M | D2004700 |
| | 775M | D2004800 |
| | 1000M | D2006200 |
| 41. | Sidewall Comb. Air Terminal (When Used) (Not Shown) | |
| | 320M | 20260701 |
| | 400M | 20260702 |
| | 520M | 20260703 |
| | 625M | 20260704 |
| | 775M | 20260705 |
| | 1000M | 20526906 |

| Item | Description | Part Number |
|------|-----------------------------|-------------|
| | Filter | A2088700 |
| | Filter Gasket | S2006100 |
| | Filter Housing Gasket, Top | S2006200 |
| | Filter Housing Gasket, Side | S2006300 |

parts4heating
800-536-1582 Fax: 866-448-9304
info@parts4heating.com



H20908600C

LAARS
HEATING SYSTEMS

Waterpik Technologies, Inc.
6000 Condor Drive, Moorpark, CA 93021 • 805.529.2000 • FAX 805.529.5934
20 Industrial Way, Rochester, NH 03867 • 603.335.6300 • FAX 603.335.3355
480 S. Service Road West, Oakville, Ontario, Canada L6K 2H4 • 905.844.8233 • FAX 905.844.2635
www.laars.com

Litho in U.S.A. © Laars Heating Systems 0206 Document 2060C