

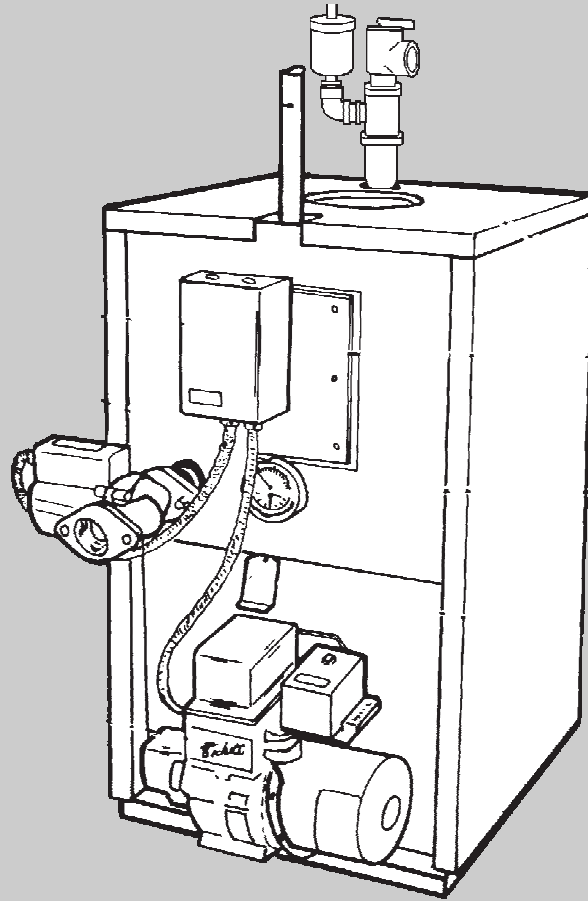

Installation,
Operation and
Maintenance
Instructions for
Newport
Oil Fired Boiler



FOR YOUR SAFETY: This product must be installed and serviced by a professional service technician, qualified in boiler installation and maintenance. Improper installation and/or operation could create carbon monoxide gas in flue gases which could cause serious injury, property damage, or death. Improper installation and/or operation will void the warranty.

⚠ WARNING

If the information in this manual is not followed exactly, a fire or explosion may result causing property damage, personal injury or loss of life.

Do not store or use gasoline or other flammable vapors and liquids in the vicinity of this or any other appliance.

Installation and service must be performed by a qualified installer, service agency, or fuel oil supplier.

TABLE OF CONTENTS

SECTION 1.

General Information

1A. Boiler Installation 3
1B. Freight Claims 3
1C. Boiler Location 3
1D. Boiler Clearances (to combustibles) 3
1E. Floor 3
1F. Combustion and Ventilation Air 3
1G. Chimney and Draft Requirements 3
1H. Jacket (normally fitted) 3
1I. Oil Burner (normally fitted) 3
1J. Boiler Controls (normally fitted) 3
1K. Oil 3

1L. Oil Storage and Pipe Layout 3
1M. Electrical Wiring 4
1N. Operation
 (Honeywell L.8124A aquastat relay) 4
1O. Domestic Water Piping 4
1P. Cleaning the Boiler 4
1Q. Cleaning the Chimney 4
1R. Servicing the Burner 5
1S. Maintenance of the Tankless Coil 5

SECTION 2.

Part Numbers

..... 11

SECTION 1. General Information

These boilers have been designed and constructed according to ASME codes using heavy gauge steel tubes and boiler plate.

The reliable heat exchanger incorporates special flue baffles to assure quiet and efficient operation and a purpose designed ceraform combustion chamber minimizes base loss and also provides a tight enclosure with the heat exchanger.

The domestic hot water coil is located at the top of the boiler in the hottest zone for an ample supply of hot water and a unique feature of its attachment is the raised coil flange which allows the use of clamping bolts rather than studs, thereby eliminating water leaks caused by broken studs.

The complete unit comes pre-assembled for easy installation and is encased by a fully insulated baked enamel jacket.

1A. Boiler Installation

For recommended installation practice reference should be made to the National Fire Protection Standard for Oil Burning Equipment (NFPA 31 - Latest Edition).

1B. Freight Claims

Inspection should be made of boiler and its components for damage upon arrival. Any claims for damage should immediately be filed against the carrier by the consignee.

1C. Boiler Location

The boiler should be positioned as near to the chimney as possible and have a minimum smoke pipe connector length of 18"(457mm).

Caution

Newport boilers must not be directly connected to a heating system using oxygen permeable tubing (see warranty). Use a water to water heat exchanger between boiler and system to prevent corrosion.

1D. Boiler Clearances (to combustibles)

Top - 6" (152mm) Front - 24" (610mm)
Rear - 6" (152mm) Sides - 6" (152mm)

1E. Floor

The boiler must be mounted on a noncombustible masonry or cement floor with no combustibles underneath.

1F. Combustion and Ventilation Air

To insure an adequate supply of fresh air for combustion and ventilation an inlet and outlet opening should be provided at floor and ceiling level. Each opening must have a minimum of one square inch (16.5 sq. cm) of free area for every 1,000 BTU/h (293kW) of input or 140 square inches (903 sq. cm) per one gallon (3.785L) of oil burned per hour. The openings must not be in a position liable to blockage.

1G. Chimney and Draft Requirements

To assure the safe and proper operation of the oil burner the boiler must be connected to a chimney having sufficient draft at all times to evacuate the flue gases to atmosphere. A draft regulator must be installed in the smoke-pipe as near to the flue as possible and adjusted to achieve an overfire draft of 0.01 ins. W.C.

1H. Jacket (normally fitted)

If not fitted, assemble panels in accordance with instructions in Figure 4.

1I. Oil Burner (normally fitted)

If not fitted, insert burner tube into boiler so that it is approximately 1/4" (6mm) from inside wall of ceraform chamber, then clamp mounting flange and bolt up to front-plate (see Figure 3).

The burner should be wired and connected to the oil line in accordance with the manufacturer's instructions.

1J. Boiler Controls (normally fitted)

If controls are supplied separately, fit them to the boiler in the positions shown in Figure 3, with jacket in place.

Circulator - 1 1/4" return tapping at front of boiler.

Tridicator - temp/press. gauge.

Relief Valve - Provide 3/4" tee and auto vent as shown on front page for air elimination.

Aquastat Relay - L8124A - 3/4" tapping in coil plate.

Fit a drain valve (not supplied) in a tee at hydronic return connection and check all connections are made water tight.

1K. Oil

USE ONLY No. 2 HEATING OIL. Do not use gasoline, crankcase draining or any oil containing gasoline.

1L. Oil Storage and Pipe Layout

Storage Tank: Consult local fire and building codes for acceptable fuel storage methods in your area.

Fuel Line: A single pipe system of not less than 3/8" OD copper tubing is recommended when fuel

storage level is not below the fuel unit. A two pipe system of not less than 3/8" OD copper tubing is recommended when lowest fuel level is below but not more than 8 feet below fuel unit.

Important: Refer to burner (pump) instructions for detailed fuel line and pump usage information. All installations must conform to local and national codes.

See Figures 5A and 5B.

Figure 5A One-pipe system - pipe and tank layout.

Figure 5B Two-pipe system - pipe and tank layout.

1M. Electrical Wiring

All wiring must comply with the National Electrical Code, NFPA 70, local codes and ordinances regarding wire size, type of insulation and enclosures etc. (see Figure 6).

1N. Operation

(Honeywell L8124A aquastat relay)

A call for heat from the room thermostat causes the relay to "make" the burner circuit and also feed the circulator provided the boiler water temperature is above the low limit setting (usually 190°F [88°C] to 210°F [99°C]). The burner and circulator then continue to run until the room thermostat is satisfied.

A high limit switch shuts off burner in the event of water temperature exceeding the high limit setting, usually 20°F (-7°C) to 30°F (-1°C) above the low limit setting.

The low limit switch and circulator maintain boiler water temperature for domestic hot water services and prevents circulation of heating system water if domestic water is not hot enough.

1O. Domestic Water Piping

1. Connect anti scald tempering valve (12) "HOT" port to hot water outlet from unit. This valve should be mounted 3" (76mm) to 6" (152mm) below the outlet and set for 120° F mixed delivery temperature or as local codes dictate (see Figure 1).

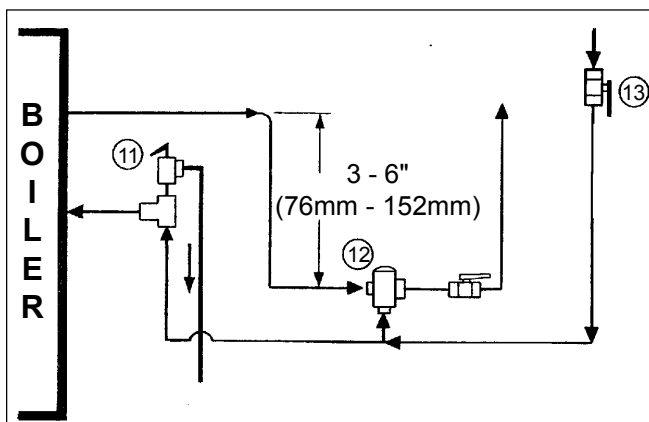

Figure 1. Domestic water piping.

2. Connect gate or shutoff valve (13) to anti scald tempering valve (12) "MIX" port, and another to the cold water inlet.
3. Connect pressure relief valve (11) (if required by codes), maximum 150 PSI as close to the unit as possible. No other valves or restrictions may be installed between the DHW coil and the relief valve.
(DO NOT USE A TEMPERATURE/PRESSURE RELIEF VALVE AS THIS IS NOT A STORAGE HOT WATER HEATER).

⚠ WARNING

Flue gases are dangerous - do not operate boiler if there is an escape of flue gas. Call a qualified serviceman and have the entire flue and venting system inspected.

1P. Cleaning the Boiler

To maintain the high thermal efficiency and a long life from your boiler, it should be cleaned at least once a year, preferably at the end of the heating season. This is particularly important as rusting can occur when the boiler is idle.

It is recommended that a service contract be arranged with a properly equipped serviceman who will be able to do the job efficiently and without mess.

1. Switch off electrical supply to the boiler.
2. Remove smoke-pipe from boiler.
3. Remove top jacket panel.
4. Unscrew the securing nuts and remove flue collector.
5. Remove baffles from flue tubes.
6. Remove burner by unscrewing the flange mounting nuts.
7. Remove soot and scale deposits from tubes with a flexible wire brush, taking care not to damage "ceraform" combustion chamber, below outer tubes.
8. Vacuum out accumulated deposits from combustion chamber through burner port, taking care not to damage "ceraform" combustion chamber, below outer tubes.
9. Replace all parts, ensuring flue-baffles are correctly located. Ensure flue collector and smoke-pipe are tightly sealed.

1Q. Cleaning the Chimney

Sweep all soot deposits from chimney and smoke-pipe once a year, preferably at the end of the heating season. It is also advisable to inspect the chimney and smoke-pipe at the beginning of heating season as birds may have built their nest inside or other material may be causing a blockage.

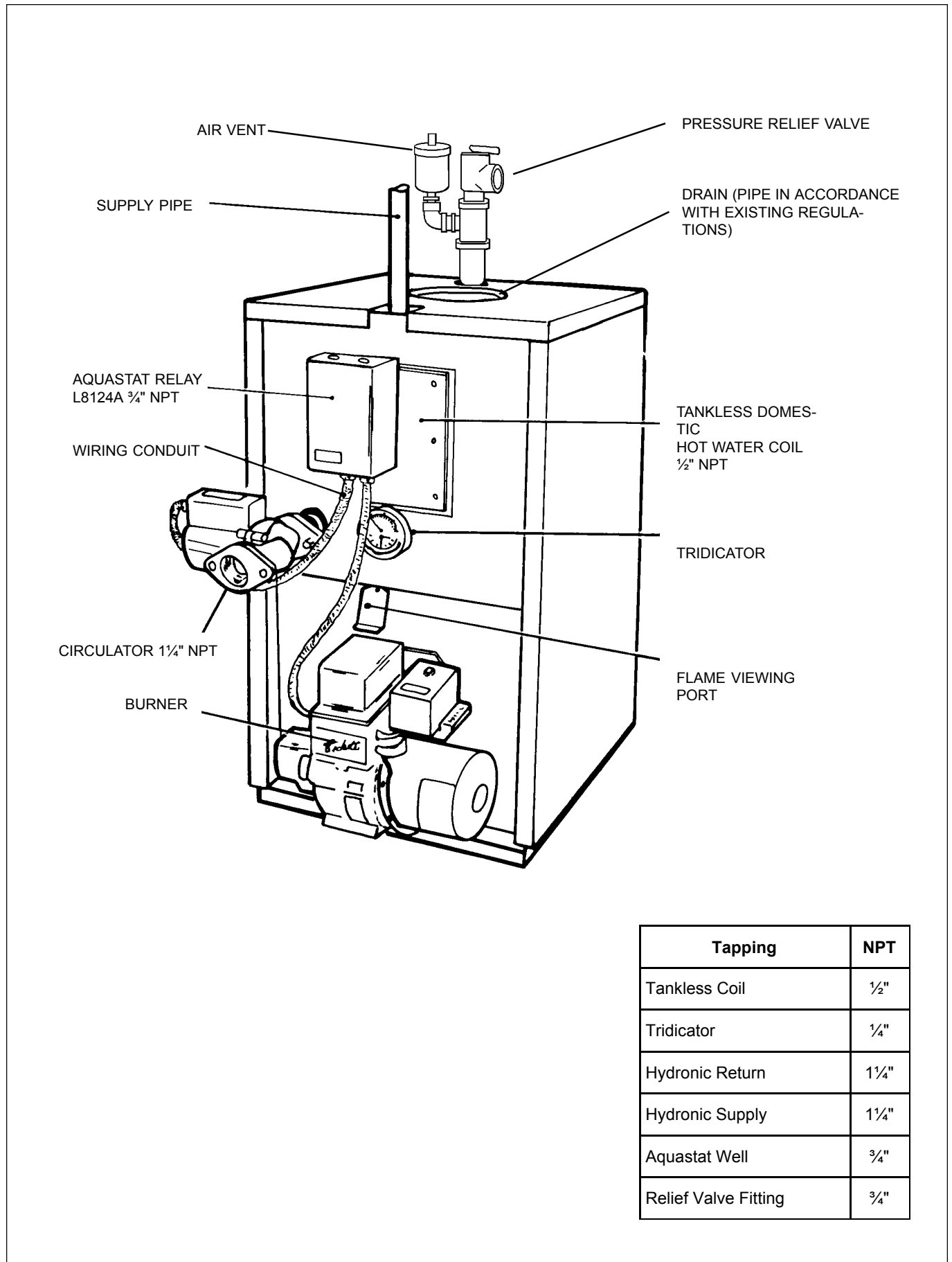

Figure 2. Components Location.

1R. Servicing the Burner

This should only be carried out by a trained and licensed service technician in accordance with the burner maker's instructions.

1S. Maintenance of the Tankless Coil

After several years of use, the water flow through the coil may become restricted by mineral deposits from the water. Mild accumulations may be removed by an acid treatment but your servicing company can advise on the most satisfactory method of cleaning or whether a replacement coil is necessary.

1T. Coil Removal

1. Switch off electrical supply and turn off water to boiler.
2. Valve off zones and drain boiler and DHW coil.
3. Disconnect the pipe connections to the coil.
4. Unscrew the eight retaining bolts from coil plate.
5. Pull out coil and clean or fit replacement as necessary.
6. Ensure gasket makes a water tight seal.
7. Refill boiler, open valves and check for leaks.

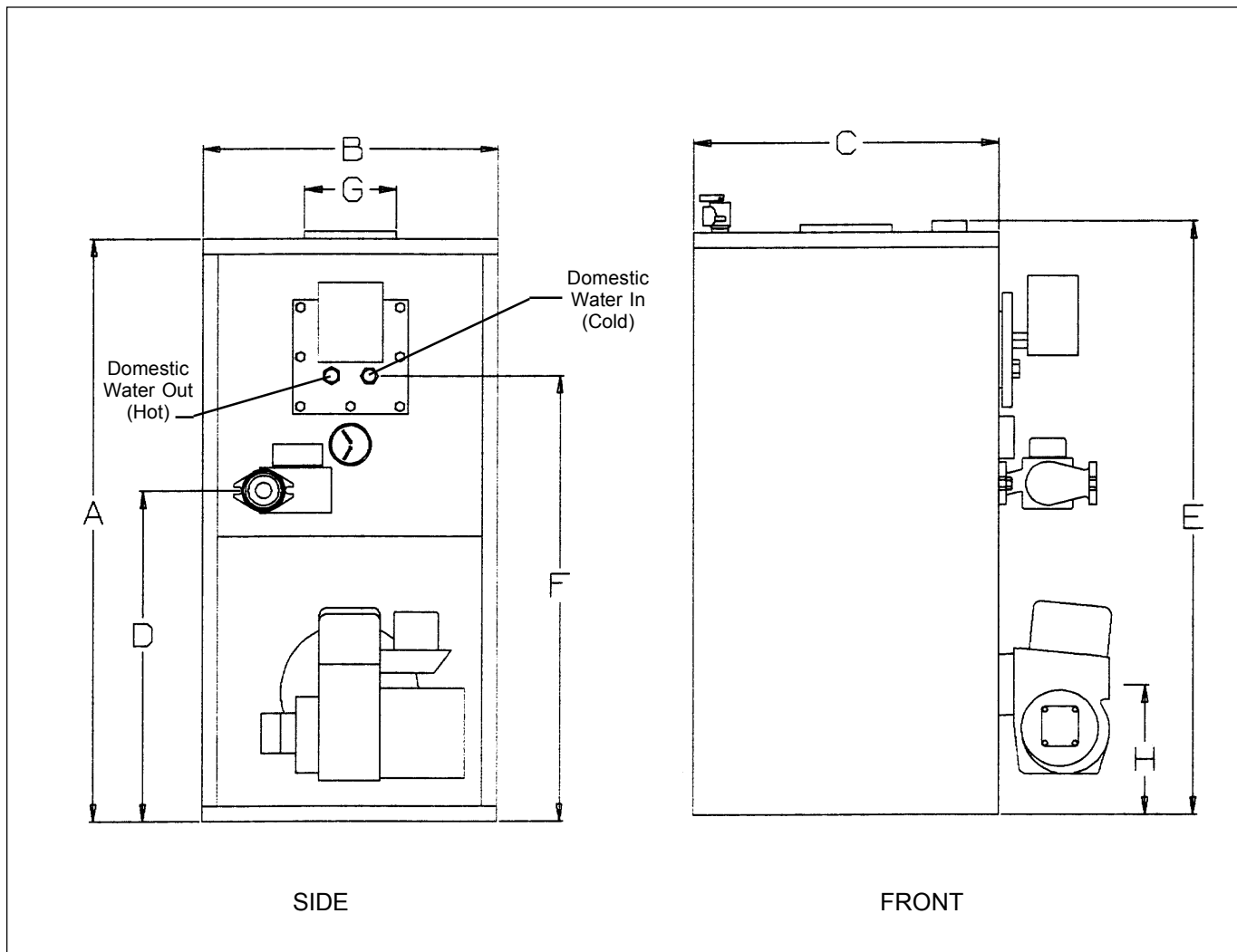

Figure 3. Dimensions.

Dimensions	REF	NP 75		NP 85		NP 100		NP 110		NP 125		NP 135		NP 150	
		inches	mm	inches	mm	inches	mm	inches	mm	inches	mm	inches	mm	inches	mm
Jacket Height	A	33	838	35½	902	35½	902	35½	902	41	1041	41	1041	41	1041
Jacket Width	B	19¼	489	19¼	489	19¼	489	19¼	489	20½	521	20½	521	20½	521
Jacket Length	C	20	508	20	508	20	508	20	508	21½	546	21½	546	21½	546
Return Tapping Height	D	19½	495	19½	495	19½	495	19½	495	22	559	22	559	22	559
Supply Tapping	E	31½	800	33½	851	33½	851	33½	851	638	965	38	965	38	965
Coil Supply Height	F	25	635	27½	699	27½	699	27½	699	31½	800	31½	800	31½	800
Smoke Outlet Diameter	G	6	152	6	152	6"	152	6	152	6	152	6	152	6	152
Burner Center Line	H	8½	216	8½	216	8½"	216	8½	216	10½	267	10½	267	10½	267
Tankless Coil NPT		½		½		½		½		½		½		½	
Return NPT		1¼		1¼		1¼		1¼		1¼		1¼		1¼	
Supply NPT		1¼		1¼		1¼		1¼		1¼		1¼		1¼	

Specifications

Firing Rate GPH		0.75		0.85		1.00		1.10		1.25		1.35		1.50	
Input MBTU/hr (kW)		85	25	103	30	120	35	133	39	150	44	160	47	177	52
Output MBTU/hr (kW)		74	21	90	26	105	30	116	34	130	38	139	40	154	48
Efficiency % AFUE		83.20		83.60		83.10		83.10		83.70		83.00		83	
Net Stack Temperature °F (°C)		375	191	312	156	353	178	371	188	351	177	386	197	417	214
Shipping Weight - lbs. (kg)		285	129	310	141	310	141	310	141	368	167	368	167	368	167
Water Content - gallons (L)		9.75	36.9	11.6	44	11.6	44	11.6	44	15.4	58	15.4	58	15.4	58.2
Coil Size (GPM)		4		4		5		5		5		5		5	

Becket Burner Specifications

AFG BURNER PURCHASED TO BECKETT SPEC. #TRI-801 FOR NP UNITS							
Boiler Model	**NP 75	NP 85	NP 100	NP 110	NP 125	NP 135	NP 150
Burner	AFG	AFG	AFG	AFG	AFG	AFG	AFG
Nozzle	.75 x 70° A	.85 x 70° A	1.00 x 80° A	1.10 x 70° A	1.25 x 80° A	1.35 x 80° A	1.50 x 80° A
Manufacturer	Delevan	Delevan	Delevan	Delevan	Delevan	Delevan	Delevan
Static Plate	3 3/8	3 3/8	3 3/8	3 3/8	3 3/8	3 3/8	3 3/8
Head Type	F3	F3	F3	F3	F6	F6	F6
Pump Pressure	100	100	100	100	100	100	100

****NOTE: A LOW FIRING RATE BAFFLE MUST BE INSTALLED PRIOR TO SHIPMENT.**

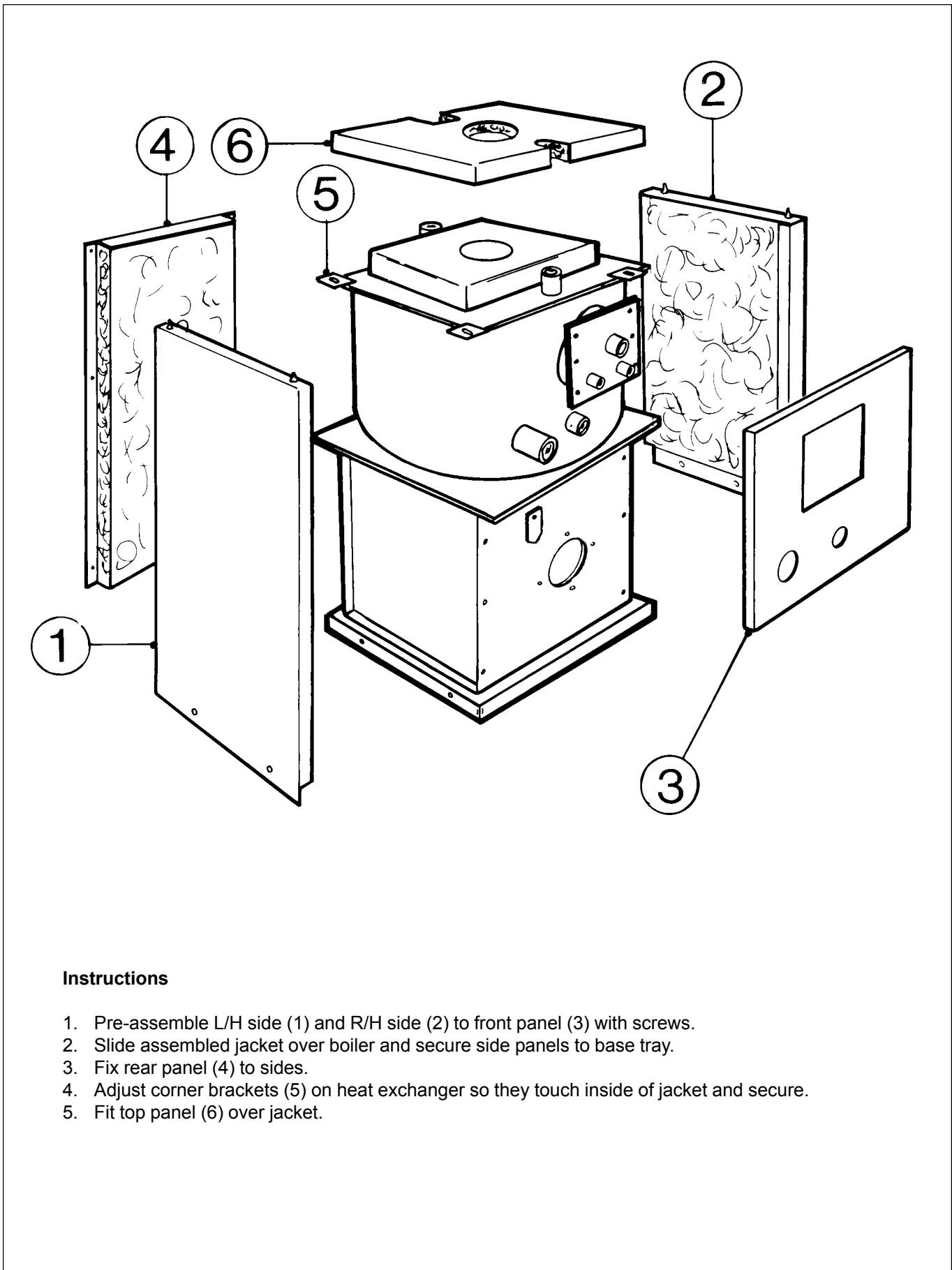

Instructions

1. Pre-assemble L/H side (1) and R/H side (2) to front panel (3) with screws.
2. Slide assembled jacket over boiler and secure side panels to base tray.
3. Fix rear panel (4) to sides.
4. Adjust corner brackets (5) on heat exchanger so they touch inside of jacket and secure.
5. Fit top panel (6) over jacket.

Figure 4. Jacket assembly.

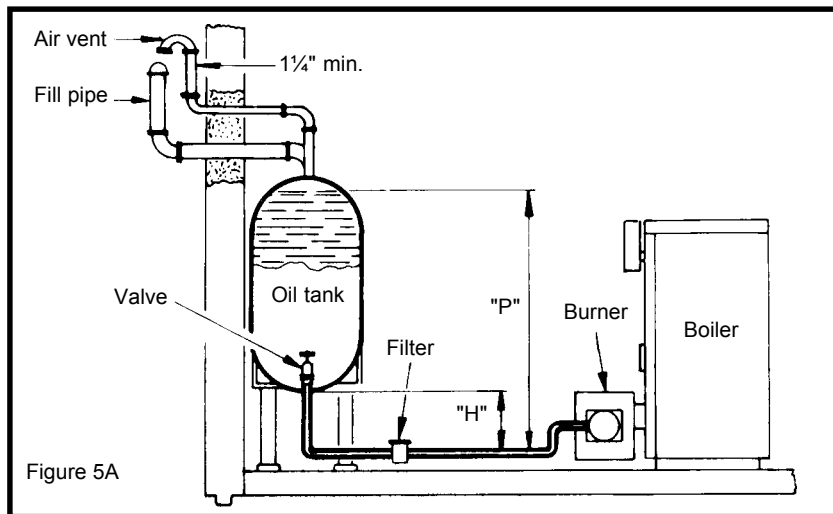

One-Pipe System

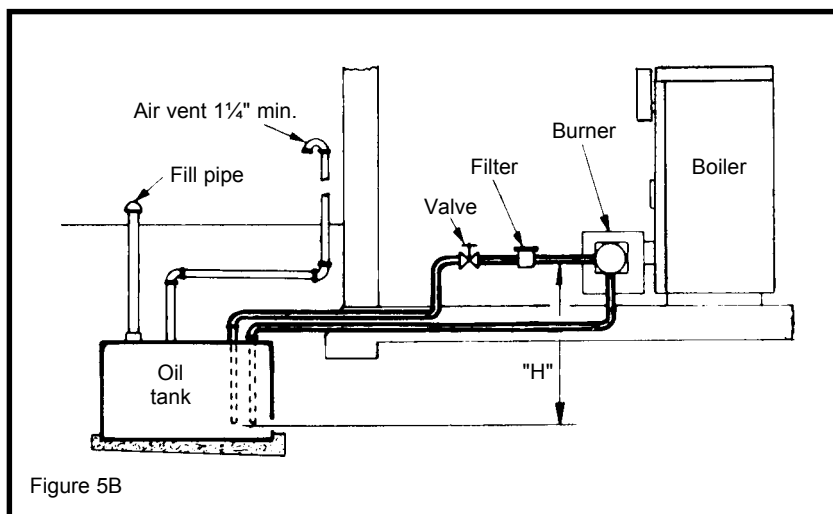

Two-Pipe System

PIPE LENGTHS					
"H"		One Pipe Gravity System			
		3/8" O.D.		1/2" O.D.	
ft.	m	ft	m	ft	m
0	0	0	0	0	0
1½	0.5	33	10.1	65	19.8
3	0.9	65	19.8	130	39.6
5	1.5	130	39.6	260	79.2
6½	2	195	59.4	325	99

PIPE LENGTHS					
"H"		Two Pipe Gravity System			
		3/8" O.D.		1/2" O.D.	
ft.	m	ft	m	ft	m
0	0	0	0	0	0
1½	0.5	115	33.0	330	100.6
3	0.9	100	30.5	330	100.6
5	1.5	80	24.4	330	100.6
6½	2	50	15.2	295	89.9
9½	2.9	25	7.6	100	30.5
11	3.4	20	6.1	65	19.8

WARNING:- The height should not exceed 13 feet (4m)
WARNING:- The vacuum must not exceed 11.44 HG. (11.44 inches of Mercury). Burner is shipped from the factory set up for two pipe system.
Important:- An external filter must be placed in the fuel line between the fuel tank and the burner pump.

Figure 5. Piping information.

 Power supply provides disconnect means & overload protection as required.

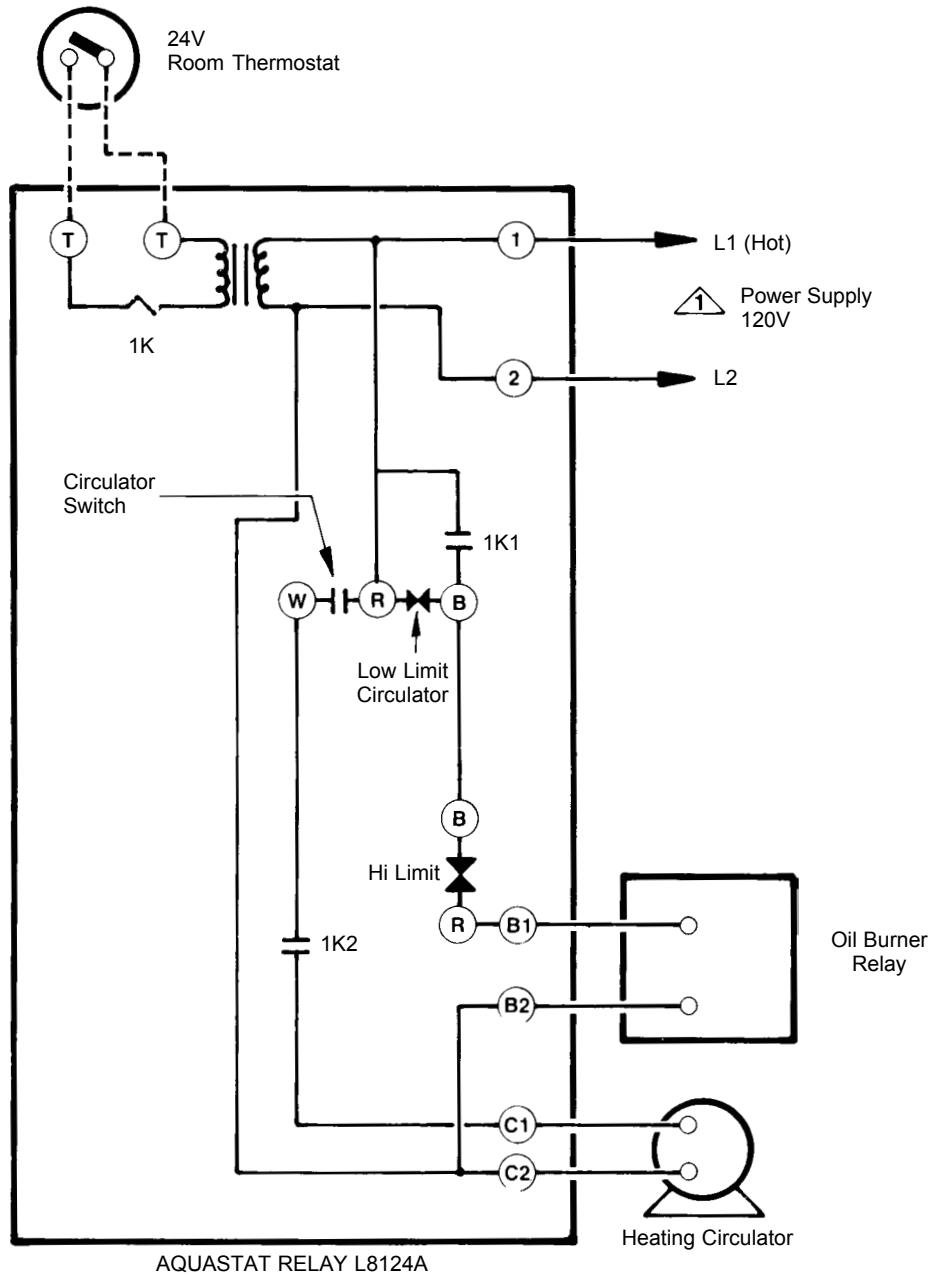

**WIRING ARRANGEMENT FOR "NP" BOILER
CONTROLLING OPERATION OF BOILER AND CIRCULATOR**

Figure 6. Wiring diagram.

SECTION 2. Part Numbers

Part Number	Description	Size	Part Number	Description	Size
51-002	Boiler Body	85/115	53-090	Flue Cover Assembly	125/155
51-056	Base Assembly (after 1990 - includes 51-058 panel)	85/115	53-108	Front Panel Assembly	125/155
2500-018	Burner Panel Assembly	85/115	53-116	Left Panel Assembly	125/155
	(before 1990)		53-124	Right Panel Assembly	125/155
51-058	Burner Panel Assembly	85/115	53-128	Top Panel Assembly	125/155
	(after 1990) use with P/N 51-056		53-136	Rear Panel Assembly	125/155
51-090	Flue Cover Assembly	85/115	53-088	Chamber	125/155
51-108	Front Panel Assembly	85/115	55-002	Boiler Body	175/200
51-116	Left Panel Assembly	85/115	55-056	Base Assembly (after 1990 - includes 55-058 panel)	175/200
51-124	Right Panel Assembly	85/115	55-502	Burner Panel Assembly	175/200
51-128	Top Panel Assembly	85/115		(before 1990)	
51-136	Rear Panel Assembly	85/115	55-058	Burner Panel Assembly	175/200
51-088	Chamber	85/115		(after 1990) use with p/n 55-056	
51-052	Baffle, 85-115 (14), 125-155 (18), All 175-200 (30)		55-090	Flue Cover Assembly	175/200
53-002	Boiler Body	125/155	55-108	Front Panel Assembly	175/200
53-056	Base Assembly (after 1990 - includes 53-058 panel)	125/155	55-116	Left Panel Assembly	175/200
2500-020	Burner Panel Assembly	125/155	55-124	Right Panel Assembly	175/200
	(before 1990)		55-128	Top Panel Assembly	175/200
53-058	Burner Panel Assembly	125/155	55-136	Rear Panel Assembly	175/200
	(after 1990) use with p/n 53-0560		55-088	Chamber	175/200